

LAZERKART

A Multi-spectrum Communications and Control System for Recreational Motorsports

Senior Design 1
Spring 2013

Group C
Evan Brown
Ryan Dixon
Tom McClelland
Adam Sefchick

Sponsored By Fun Spot, Inc.

Submitted 4-25-2013

Table of Contents

1.0	Executive Summary	1
2.0	Project Description	2
2.1	Motivation and Goals	2
2.2	Objectives	3
2.3	Specifications and Requirements	4
2.4	Sponsorship Description	6
	2.4.1 Motivation	6
	2.4.2 Sponsorship Agreement	7
3.0	Research	9
3.1	Existing Similar Systems	9
	3.1.1 Mario Kart	9
	3.1.2 Mario Kart In Real Life	9
	3.1.3 Commercially Available MILES	11
3.2	Technologies	11
	3.2.1 Photo-detection	11
	3.2.2 IR Communication	13
	3.2.2.1 Technology Determination	13
	3.2.2.2 IR Transmitter	14
	3.2.2.3 IR Receiver	14
	3.2.2.4 Pulse Width Modulation	15
	3.2.3 ZigBee Communication	16
	3.2.3.1 Technology Selection	16
	3.2.3.2 The ZigBee Specification	17
	3.2.3.3 Adaptation to LazerKart	18
4.0	Hardware and Software Design Details	19
4.1	Flow Charts	19
4.2	Power Subsystem	21
	4.2.1 Power Supply Characteristics	21
	4.2.2 Rectifiers	22
	4.2.3 Simulations	23
	4.2.4 Regulators	24
	4.2.5 Batteries	29
4.3	Microcontroller	30
	4.3.1 Requirements	30
	4.3.2 Selection Criteria	32
	4.3.3 Selection Process	32
	4.3.4 MCU Selection	34
	4.3.5 MCU Technologies	34
	4.3.5.1 Digital I/O	34
	4.3.5.2 Interrupts	34
	4.3.5.3 Pulse Width Modulation	35
	4.3.5.4 I ² C	37

	4.3.5.5 UART	37
	4.3.5.6 MSP430 Pin Diagram	38
	4.3.5.7 Components	39
	4.3.5.8 Traces	40
4.4	PCB Diagram	41
	4.4.1 Manufacturer	41
4.5	Item Acquisition	42
	4.5.1 Implementation Optics	42
	4.5.2 Optical Sensor Subsystem	42
	4.5.3 Continued Research and Initial Circuit Design	43
	4.5.4 Optimizing LED Sensor Circuit	44
	4.5.5 Photodiodes/Phototransistors	46
4.6	Software design	47
	4.6.1 Headers	47
	4.6.2 Variables	48
	4.6.3 Setup	49
	4.6.4 Interrupts	49
	4.6.5 Timer A	49
	4.6.6 Main Loop	49
	4.6.7 Interrupt ISR	50
	4.6.8 Item Pickup	50
	4.6.9 Boost Pad	50
	4.6.10 Hit Detected	50
	4.6.11 Trigger Pulled	50
4.7	IR Emitters/Receivers	52
	4.7.1 IR Transmitter	52
	4.7.2 Tagger Housing	54
	4.7.3 IR Receiver	54
	4.7.4 Receiver/Brake Light Housing	56
4.8	Throttle Linkages and Servo	56
	4.8.1 The Engine Governor	56
	4.8.2 Servo Mounting	57
	4.8.3 Servo Bracket	58
	4.8.4 Servo Location	58
	4.8.5 Servo Arm Movement	59
	4.8.6 The Servo	59
	4.8.7 Controlling the Servo	60
4.9	Optional Modules	61
	4.9.1 8x8 LED Matrix Display	61
	4.9.2 Accessory LED lighting	63
	4.9.3 ZigBee Mesh Network	66
	4.9.4 Audio Components	67
	4.9.4.1 Sound Effects Concept	67
	4.9.4.2 Software/Hardware	67
	4.9.5 No Bumping Warning	68
	4.9.5.1 Motivation	68

4.9.5.2	Accelerometer Requirements	69
4.9.5.3	Selection	69
4.9.5.4	Output Voltage	69
4.9.5.5	Interaction With Microcontroller	69
4.9.6	Hand Held IR Transceiver	70
4.9.6.1	IR Receiver	71
4.9.6.2	IR Transmitter	71
4.9.6.3	Transmitter Power	72
4.9.6.4	Receiver Circuit	73
4.9.6.5	Transmitter Circuit	73
5.0	Design Summary	75
5.1	Flow Charts	75
5.2	Hardware Summary	77
5.2.1	Power System	77
5.2.2	Item Acquisition	78
5.2.3	PCB	79
5.2.4	Servo	79
5.2.5	LED Accessories	79
5.2.6	IR Transmitters and Receivers	80
5.3	Software Summary	80
5.3.1	Item Pickup	80
5.3.2	Boost Pad	80
5.3.3	Hit Detected	80
5.3.4	Trigger Pulled	81
6.0	Prototype Construction and Coding	82
6.1	Building the Modules	82
6.1.1	Connectors	82
6.1.2	PCB Housing	83
6.1.3	Servo Mount	84
6.1.4	Weapons/Boost Pickup Sensor	84
6.2	Installation	84
6.2.1	Throttle Control Servo	85
6.2.2	LazerKart Main Module	85
6.2.3	Item Pickup Sensor	86
6.2.4	IR Transmitter/Receiver	87
6.2.5	Ready Light/8x8 LED Display	88
6.2.6	Trigger	89
6.2.7	Brake Light/Stop Lamp Switch	90
6.2.8	Accessory Lighting	91
6.3	Software Development	92
6.3.1	Testing Platform	92

7.0	Testing	94
7.1	Subsystem Tests	94
7.1.1	Pickup Sensor Testing	94
7.1.2	Boost Zone Sensor Testing	95
7.1.3	Microcontroller Testing	96
7.1.3.1	Item Pickup	96
7.1.3.2	Boost Item	96
7.1.3.3	Lazer Item	97
7.1.3.4	Boost Pad	97
7.1.3.5	Lazer Hit	97
7.1.3.6	Possible Failure Causes	98
7.1.3.6.1	Vibration and Loads	98
7.1.3.6.2	Shock	98
7.1.3.6.3	User Damage	99
7.1.3.6.4	Water	99
7.1.4	Servo Testing	99
7.1.5	IR TX/RX Testing	100
7.1.6	Power systems testing	101
7.1.6.1	AC Coil Testing	101
7.1.6.2	Rectifier	102
7.1.6.3	Regulators	102
7.1.7	Optional Module Testing	103
7.1.7.1	Accessory LEDs	103
7.1.7.2	Audio Components	104
7.1.7.2.1	Power Consumption	105
7.1.7.2.2	Sound Effects	105
7.1.7.3	No Bumping Testing	106
7.2	Single Kart Tests	107
7.2.1	Transmitter / Receiver Location	107
7.2.2	Photo-detection Location	108
7.2.3	Triggers and Item Lights	109
7.2.4	Speed Control Testing	111
7.3	Multi-Kart Testing	111
7.3.1	Two Kart Testing	112
7.3.2	Four Kart Testing	112
7.3.3	Full Race Testing	113
7.4	Game-play Mechanics Testing	114
8.0	Administrative Content	115
8.1	Milestones	115
8.1.1	Spring 2013-Senior Design I	115
8.1.2	Fall 2013-Senior Design II	116
8.2	Equipment	116
8.3	Accessories	117
8.4	Consultations	117
8.5	Budget	119

9.0	Commercial Implementation	120
9.1	Track Preparation	120
	9.1.1 Track Selection	120
	9.1.2 Game Setup	120
9.2	Staff Training	122
	9.2.1 Game Operation Training	122
	9.2.2 In-Race Troubleshooting	122
	9.2.3 Off Track Troubleshooting	122
9.3	Maintenance Training	123
9.4	Stocking and Ordering Spare Parts	124
10.0	Summary and Conclusions	125
	Appendix A References	
	Appendix B Copyright Permissions	

1.0 Executive Summary

Since the 1990's, many millions of people who play video games have played a game from the Mario Kart series produced by Nintendo. The game pits up to 8 go-kart racers against each other to see who can finish the race first, with one caveat, each car can obtain randomly selected items placed around the racetrack that can help them win the race. The question that was asked amongst the group was "How fun would it be to do this with real go-karts?" So, the main objective of this project, called LazerKart, is to produce a similar experience to the Mario Kart video game that would immerse the driver in a battle race that would require skill and a little bit of luck. The Overall design would be relatively inexpensive, could be applied to existing go-kart venues, and would try to capture the imaginations of those who have played the game along with those who haven't.

The LazerKart concept involves multiple go karts, a go kart racetrack, and the system integration. The most basic implementation will allow the driver of a Kart to obtain an "item" by driving over a colored marker which is located on the track. Once driven over, a microcontroller on board the kart will randomly generate an item and illuminate a "ready" light. When pressed, a trigger button located on the steering wheel will activate the acquired item. Initially, the item could be an Infrared "lazer cannon" that cuts a target karts' throttle down to idle for several seconds or a turbo booster that briefly accelerates the kart beyond its normal top speed.

In order to make LazerKart realizable, a low-power distribution system and microcontroller must be feasibly employed to sustain an optical sensor subsystem, an IR emitter/receiver subsystem, a throttle control subsystem, and still have headroom for additional components heretofore unmentioned. Each of the main systems and subsystems must undergo extensive research, design and testing. It must be able to operate outside in broad daylight, at night, in varying daily weather and all the while demonstrate a fun, balanced gameplay mechanism that makes the experience worthwhile. All testing will be done outdoors on asphalt at a car lot using a temporarily donated go-kart from The Fun Spot in Orlando, FL.

As the basic LazerKart implementation becomes fully functional and passes all tests, other subsystems and extensions of existing systems will be designed to enhance the overall experience. The plans for this next stage of development include adding sound effects to supplement the item usage, an LED display (segment or dot-matrix) to replace the ready light, ZigBee wireless networking to allow for more interesting items and to maintain leader boards, RGB LED accessory lighting that visually enhances the game, and a handheld lazer cannon for two-seat go karts, among others.

2.0 Project Description

2.1 Motivation and Goals

Many people have had the exciting privilege of playing the Mario Kart video games, and some of those people have also driven an actual go-kart at a recreational center on a go-kart track. In both instances, all the respective go-karts achieve approximately the same top speed, and if you pit two skilled drivers against one another, it becomes difficult for either one to pass the other and take the lead. The difference between the two is that, in Mario Kart, there are easily obtainable items, or power-ups, that are placed around the race track that can be used to slow opposing karts down or speed up one's kart in order for one to take the lead against the other competitors. This was the inspiration for the idea to incorporate such a concept from the video game world into the real world.

The technologies involved in bringing LazerKart to life are interesting and diverse enough to allow the group to maintain a high level of dedication. From the long range, broad-daylight carrier frequency encoding IR transmission, to figuring out how to get sufficiently reliable DC power from a small engine AC lamp coil, to implementing an optoelectronic color sensing system, to electronically overriding the engine's throttle and integrating the system with a low-cost microcontroller, there are a variety of topics to be researched and developed. Additionally, there will be room for additional components that will further make LazerKart more interesting, time permitting.

The fun part about a project like this is going to be the testing phase. This will involve a considerable amount of time driving the go karts and fine tuning the aspects of the system that will make the execution seamless, balanced, and enjoyable.

The ultimate goal to be reached in the design process is to create a fully functional, multiplayer go kart experience that allows for any number of go karts (usually about 16) to be driven with the ability to shoot other go-karts with a time-limited IR lazer cannon and make them stop for just enough time to be passed by the shooter, but only after acquiring the IR weapon activation from the marker on the track. The intermediate goals are as follows:

- Obtain a reliable donor go-kart and a testing facility.
- Develop each subsystem individually with any requirements from neighboring systems taken into consideration.
- Create Prototype (bread/perfboard) units to apply to the donor kart for testing.
- Have a working concept go-kart to demonstrate basic (un-tuned) functionality by beginning of Summer 2013.

- Obtain a second (perhaps a third and a fourth, eventually) donor go-kart and set up the prototype system to begin gameplay mechanics testing
- Vigorously test the system using standard and worst-case scenarios and all those in between (on and off racetrack).
- Unify the components and sensors onto PCB(s) and standardize any connections.
- Create weatherproof and shock-absorbent enclosures for all components. Fabricate all mounting hardware.
- Install finalized system on a set of go-karts and demonstrate LazerKart.

Once these goals have been met, the group has expressed interest in potentially marketing the LazerKart system to go-kart venues. Unmentioned in the above goal list is the development of the additional subsystems and expansions such as the ZigBee network and LED accessory lighting. These are not critical to the project requirements, but will be carefully considered and implemented given any extra available development time left over after completing the project requirements.

2.2 Objectives

The main objective of this project is to make sure that LazerKart is fun and a worthwhile enhancement to the typical go-kart experience. In order to do that, multiple play tests will have to be held with as many scenarios as possible in order to bring a fun balance to the game. LazerKart should be attractive to drivers of all skill levels and ages. The gameplay will allow more control of the karts to competitors, but the venue will be able to override the entire system when necessary. What is equally as important, if not more so than the fun factor is the safety of the karts. LazerKart must be deemed safe to operate on existing go kart racetracks. The system will be expandable to integrate as many go karts as necessary.

From an academic standpoint, the objectives are to utilize the skills that have been acquired throughout the UCF Electrical Engineering curriculum and showcase them in such a way that reflects on the talent of the group as well as the inspiration and top-tier education that the UCF faculty has provided. There should be no question that after seeing a demonstration of LazerKart in action, the group will have demonstrated excellence in designing a fully functional, well-engineered product that exhibits both teamwork and individual effort in multiple disciplines within the Electrical Engineering domain. The various subject areas to be demonstrated include but are not limited to: semiconductor devices, analog and digital communication, operational amplifiers, low-voltage power systems, and embedded systems.

An additional objective is to design LazerKart in a modular fashion, with easily obtainable components, with low cost and simplicity such that the system could be marketable and easy to maintain.

2.3 Specifications and Requirements

The first donor go kart that will receive the LazerKart treatment is one from Fun Spot (fig.) in Kissimmee, FL. It is powered by a 9hp Honda GX-270 4-stroke gasoline engine. The engine supplies a 3A max AC lamp coil that will be the source of all things electrical with LazerKart. The voltage supplied by the coil



Fig 2.3.1: Donor Go-Kart

varies with RPM of the engine. At idle, 9Vrms was measured with respect to floating ground (not the frame), while at full throttle, ~25Vrms was measured. This AC voltage needs to be converted to DC to supply to the electronic subsystems. The MCU and the sensor op amps will require 3.6 V to operate, while the IR system will require 5V. Other supply voltages can be obtained if necessary. The throttle will have either a bidirectional solenoid or a servo mounted on a bracket to be able to increase throttle beyond the foot pedal limit and to cut the throttle to idle. This servo will be activated by the IR subsystem and speed boosts mentioned later.

The power up acquisition subsystem will need to be responsive to the effect of the go kart going approximately 20mph over a marker that is 24in. x 12in. and needs to be unaffected by ambient daylight that might seep around to the underside of the go-kart. As of this writing, this system needs to differentiate

between two different colors, one for item power-ups and one for turbo speed boosting.

The IR lazer tag subsystem must function in broad daylight and not draw more than 1A of current. Although the other subsystems draw very little current, it is important to keep enough headroom to possibly incorporate future subsystems. To operate effectively in daylight, the IR emitters and receivers will communicate via a 30-56KHz square wave carrier frequency that will encode 1's and 0's that the IR system will use to tell the MCU to activate the throttle idler.

The LazerKart code will integrate all of the subsystems onto a Texas Instruments MSP430 G2553 microcontroller. It will draw up to 100mA at full load and will have a 3.6V operating voltage. One microcontroller has enough pins to run the basic system integration. If any of the expansion subsystems are implemented, I²C will be utilized accordingly and more microcontrollers will be added.

To summarize the basic operational requirement for LazerKart: a kart will be driven over a colored marker, the optical power-up sensor under the kart will detect the color of the marker and set the corresponding input on the MCU. If the marker was an item marker, the MCU will randomly select from a list of weapons or boosters that the driver can engage with a button on the steering wheel. A weapon item will utilize the IR lazer cannon (transmitter) and will be used to aim at the IR receiver on the rear of the other karts. If a receiver is hit, the IR system will send a signal to the MCU to slow the kart to idle for several seconds. If the marker had been a turbo boost marker, or if the power-up generator resulted in a turbo boost, the MCU will receive a signal (either from the button or the optical sensor) to increase max throttle temporarily.

As mentioned earlier, the donor go-kart provides electrical power via the AC coil, however, the LazerKart system could very well be run off of rechargeable battery power if the designated go karts have no coil or are perhaps electric go karts. The following tables represent both the supplied power from the AC coil and a rough estimate of the power requirements for the basic implementation of the LazerKart system to function.

Max Available Power	Idle voltage	Max throttle voltage
75W(3A max)	9Vrms	25Vrms

Fig.2.3.2: AC coil specs

Subsystem	Voltage	Est. Current	Est. Power Consumption
IR "lazer tag"	5V	1A	5W
Microcontroller	3.6V	100mA	0.36W
Throttle-Linked Servo	5V	500mA	2.5W
Indicator LED/Stop lamp	3.6V	30mA	.108W
Item Acquisition Sensor	5V	30mA	.15W
Total		1.66A	8.108W

Fig.2.3.3: Estimated current and voltage requirements

2.4 Sponsorship Description

2.4.1 Motivation

When the decision was made to start planning how the project was going to be executed, a major concern was the demonstration of the project and whether or not we would use full-scale go karts or just use small RC cars for proof of concept. The first task was to choose how to acquire go karts if a full-scale version of the game was indeed the direction the project would take, since there is not enough money in our senior design budget to purchase the go karts needed.

The solution was to find an establishment that would allow access to multiple go karts. After considering several options the decision was made to contact Fun Spot Attractions in Orlando, FL. Shortly after making contact with the CEO/owner of Fun Spot, Mr. John Arie Sr., an onsite meeting was scheduled to further discuss the concept of the game and what would be expected on both ends of the project in order to make access to the go karts a possibility.



During our first meeting the group presented Mr. Arie with the game play dynamics of Nintendo's Mario Kart 64 and how the concept could be

implemented in a realistic setting. The presentation included a description of how successful Nintendo's Mario Kart 64 has been since its release in December 1996 and how the game is still being played today as well as the release of many newer versions for other Nintendo gaming consoles. The presentation included examples of other similar projects that had been attempted such as the one designed by Waterloo Labs encouraging others to expand on the idea which further validated the motivation and desirability of such a game. Mr. Arie was impressed by the presentation and was willing to give the group access to the go karts as needed.

2.4.2 Sponsorship Agreement

Another meeting was scheduled so that the group could become acquainted with some of the staff members that are in charge of the tracks and the go karts, as they would be a helpful resource if mechanical assistance was needed. Mr. Arie gave permission to take one of the go karts during the beginning stages of R&D so that we would have convenient access. Mr. Arie also gave permission to use the go karts tracks as a way to test the design and gameplay dynamics once working prototypes were completed. The group was given a tour of Fun Spot Attractions and the current large-scale expansion of the park such as the new roller-coasters and waterpark being built along with the renovation of one of the four go kart tracks. We were given the opportunity to ride the go karts around each of the tracks multiple times in order to decide what track would suit the game when testing. Since Lazer Karts is a multiplayer game it was stated that at least two karts would be needed in the long run and Mr. Arie generously expressed that the use of as many Karts as needed to develop the game is granted.

Another key topic of the sponsorship discussed, considering the design of Lazer Karts is successful, was the possibility of permanently converting and designating one of the four tracks to a Lazer Karts track, which would go hand-in-hand with the current expansions and additional rides being built. The conversion of the track would require the use of around 15 karts and give the group a large scale project to undertake once a working prototype was built, potentially leading to a post-graduation employment opportunity for the four of us working on the project. It is in the sponsorship agreement that if the design is successful for the first few Lazer Karts that the additional Karts conversion cost would be covered by Fun Spot.

One go-kart feature that was mentioned was the addition of LEDs. The group will attempt to integrate programmable LED strips into the game of lazer karts. These lights will display different patterns for the different functions of the microcontroller including flashes, cascading and dimming effects when the user is either hit, fires or picks up a weapon/boost from the track respectively. The lights will add excitement and grandeur to the game, attracting customers.

While communication between Fun Spot and the group is ongoing, both sides are very pleased with the outcome thus far and the potential opportunities for an ongoing business relationship. The group plans on giving multiple presentations to Mr. Arie and several staff members using the prototypes so that they are kept aware of the current progress of the project.

3.0 Research

3.1 Existing Similar Systems

3.1.1 Mario Kart

In 1992, video game maker Nintendo released "Super Mario Kart" for the Super Nintendo Entertainment System. Since then, Nintendo has released 8 more hugely popular Mario Kart games selling a total of over 90 million units. The Lazer Kart system was inspired by a desire to bring the game mechanics that make this video game franchise so popular to the real world. As such, a brief overview of the Mario Kart game is appropriate here.

Mario Kart is a Go-Kart racing game, but with the important difference of "Items" that are picked up as races travel around the track. These Items give the racer a brief advantage in the race and add a new dimension to traditional racing. The items take fanciful forms such as magical mushrooms, enchanted turtle shells, power stars, etc. The physical appearance of the item is not important to gameplay, so this report will focus only on their functions. While the exact items vary from game to game, they can generally be divided in to two categories. The first category of Items give the racer a temporary speed boost of approximately 25% lasting between 3 and 7 seconds. Some items give only one such speed boost while others give multiple speed boosts to be used as directed by the racer. The second category of Items is designed to slow down one or more opposing racers. Generally, this is accomplished by a racer positioning themselves behind an opponent and firing the item at the opponent. If the item hits the opponent, that racer is slowed or stopped for a brief period of approximately 5 seconds. This gives the first racer an opportunity to easily pass the opponent. These are the types of functions that this project aims to recreate.

3.1.2 Mario Kart In Real Life

Our Lazer Kart System will not be the first attempt to bring the mechanics of Mario Kart to the real world. Late in 2012, a group of engineers from National Instruments known as

Waterloo Labs set out to recreate the Mario Kart experience at a local go-kart track. Being National Instruments engineers and possibly sponsored by the company, they developed their system using high level NI equipment based around a cRIO controller and several NI modules.

In their system, actual physical items are used. Foam rubber items embedded with RFID tags are hung around the track to be grabbed as racers drive by. These items are then either thrown or launched at other karts where the kart's

RFID system detects them and takes appropriate action. When an item is used that would slow down the racer, it causes the computer to lock the brakes with a pneumatic actuator and lock the steering wheel hard over. This causes a crash into the race track wall. Each kart is also equipped with a wireless router for communication and two servos to control the engine throttle. See the following diagram (Figure 3.1.1) for an overview:



Figure 3.1.1 Waterloo Labs Mario Kart System Block Diagram
Reprinted with Permission

They developed a very powerful and robust system, but we noted some drawbacks to their approach. First of all, items must be manually reset after every lap. This is not a good approach for a commercial site desiring high throughput and limited labor costs. Second, the thrown/ launched items create a hazard on the track. While they may not damage the karts, they could get stuck in the wheel area or next to the very hot engine area. Also, the wear and tear on the items would necessitate frequent replacement. That is also undesirable. In addition, pneumatic systems would require frequent refilling, causing downtime as well as increased labor and hardware costs. Next, the parts they used, especially the cRIO and modules, are very expensive. The cRIO controller alone costs over a thousand dollars. They are also large, heavy, and delicate. Finally, a commercial entity can limit the possibility for kart damage and injuries by not forcing the wheel to lock hard over and the brakes to lock up. That is simply unsafe. When our karts are “hit”, they will not crash, but only cut the engine to a coast for a few seconds. The driver will retain complete control over steering.

There are some things our project can build upon from Waterloo Lab's. Our project will also use servos to control the engine, but we can do it with one, not two. We will also use wireless communication, but we will use small, light, efficient ZigBee modules instead of Linksys Wi-Fi routers. Instead of actual items

being grabbed and launched, we will use virtual items, pickup pads, and IR “lazers” to achieve the same type of game play, but at greatly reduced cost, complexity, and increased safety.

3.1.3 Commercially Available MILES

As stated the previous section, physical items increase cost, complexity, man power required, and downtime. Therefore, we will use infrared transmitter and receivers as the “lazer” system in our karts. Many people have played a recreational form of “Lazer Tag”, and commercial systems are available for off the shelf Lazer Tag play. However, we require something more powerful. Our karts will operate outdoors in all weather all year round. For inspiration, our system looks the United States Military. In the 1980's the US Army introduced a training system that would more accurately simulate force-on-force engagements. These systems use military grade IR transmitters and receivers to simulate small arms fire, “hits”, and “kills”.

The systems have been upgraded over the years and are now provided by Cubic Corporation. A smaller, civilian industry has sprung up in recent years to provide high quality recreational lazer tag gear to the general public by taking advantage of the decreasing price of electronics of the last two decades. One such company is Combat T.A.G. LLC. They offer very high quality lazer tag systems and equipment. They offer a full range of kits, modules, and components ranging from full up systems that are ready to go out of the box to subsystems that can be integrated together by the end user to individual parts. Their kits are built behind the Vishay Semiconductor TSOP4856 IR Transmitter and the 6100 IR Receiver. These appear to be high quality parts that are marketed as being immune to ambient light, designed for outdoor applications, and have a range of 45 meters. While we won't be needing any of the pre-built modules or kits that are commercially available, we will be using the 4856 IR Transmitter and the 6100 IR Receiver that are at the heart of high quality commercial systems.

3.2 Technologies

3.2.1 Photo-detection

One of the key technologies involved in creating LazerKart is the concept of Photo-detection. For the gameplay aspect of the entire system to work, there needs to be two different types of identifiers, or markers, on the track. When the car drives over said marker, a sensor will determine which of the two different markers was driven over. One of the cheapest ways to make this happen is through photo-detection. When light is incident upon a photodiode junction, the photons from the light release electron-hole pairs within the depletion region which are then accelerated towards the photodiode terminals, establishing a current. With greater light intensity, there will be a greater current.

The basic idea for LazerKart is that each of the markers will be a different color and a constant-on light source located under the kart will shine down onto the ground and cause the color from the marker to reflect back up to a sensor. The inherent problems with ambient light and light reflected off the road will be discussed momentarily. Assuming colored markers are the only objects reflecting light, otherwise there is zero light reflection, we can use this model and apply it to photodiodes. Two photodiodes will be used as the sensors, one to sense each of the colored markers. Each photodiode will have a colored filter placed over the lens and the surrounding sides will be contained within an enclosure. Ideally, the desired effects of the photodiodes would be for each to respond solely to the color it is supposed to detect, however that is not the case, as typically each will respond to all visible light wavelengths.

In the real world, each color-filtered photodiode will exhibit a response that is greatest at the filtered wavelength, with lesser response at decreasing and increasing wavelengths. In figure (3.2.1.1), two simplified responsivity curves are shown to demonstrate how two filtered photodiodes' responses can potentially overlap.

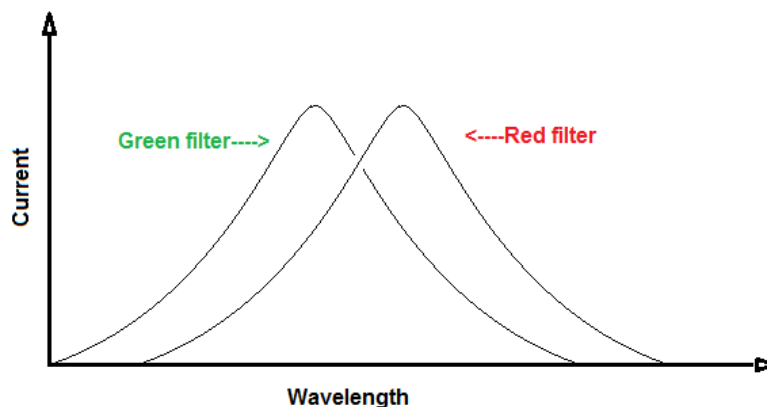

Figure 3.2.1.1: Simplified photodiode spectral response curves

These curves assume a constant spectral response throughout all visible wavelengths; as it turns out however, real photodiodes tend to have varying spectral response. Many photodiodes are manufactured with peak spectral response in the IR wavelength range (740-1100nm and greater), with diminished response at lower, visible wavelengths.

The current generated by each photodiode itself is pretty much useless until it is incorporated into a current to voltage converter. The current to voltage converter is an operational amplifier configuration in which the current generated by the photodiode (connected to the op-amp input) is multiplied by a feedback resistor from the output to the input. This product results in a voltage output that varies with the intensity of the light incident upon the photodiode. To take advantage of this circuit, the idea is to have both of the filtered photodiodes connected in two

separate current to voltage converters and “capture” whichever output produces the higher voltage, contingent upon which colored marker is detected.

This is where the ambient light and road-light reflectance becomes an issue. Since the light source is constantly on, light is constantly being reflected off of the road, and underneath the kart is very shady, but it is not perfectly dark, so there will be ambient light leaking through to the photodiodes. In order to prevent the current to voltage converter from reacting to the unwanted light two solutions are introduced:

- 1) Use a UV LED as the light source and neon paint for the markers
- 2) Establish a threshold voltage about which the current to voltage converter must cross to demonstrate an output response.

The threshold will be set based on testing of the photodiodes’ responses to the colored markers. Once the threshold is breached, output will be allowed to go to a dual comparator network. Both current to voltage converters can be allowed to breach threshold, but one will be higher than the other depending on which colored marker is currently being detected. The comparator network will virtually guarantee that only one color is detected at a time for error-free color detection.

The comparator network will simply consist of two comparators. Both of the current to voltage converter outputs will be the inputs to the comparators, but they will be opposite of one another with respect to each comparator.

3.2.2 IR Communication

3.2.2.1 Technology Determination

For the initial brain storming about the project, three different technologies on how best to implement the game into the karts were discussed. The original suggestion was to incorporate a augmented reality unit in the karts to accurately represent the video game style that was to be mimicked. This would involve creating a head unit for the driver to wear, and the need to devise a way to accurately track each individual car as it maneuvers around the track. Using this system, it would be possible to immerse the drive in a semi-virtual world. While the end product, as envisioned, could be amazing, it was determined that as a practical and commercial matter, it would not be feasible at this time.

Another option considered was the use of a kart mounted heads up display (HUD), or a kart mounted display unit. By attaching a display to the kart, you could add the video game element to the race, without requiring headgear for the rider. Communication could be done wirelessly between karts, and the game could run on an off kart base unit. With the HUD, racers would have to ability to see the real karts and have digital displays such as those seen on aircraft, and use that to shoot at the opposing players. For the standard video display unit, an digital recreation of kart and track positioning could be displayed on the unit.

Ultimately, it was decided that these would also not be practical for the purposes of the project.

Infrared LED communication was the most obvious choice for our project. The technology is widely researched and available, and the cost is reasonable. The project build would need only a IR LED transmitter unit and a receiver unit on each kart, along with a trigger. No augmentation would be required, and the chance of the driver being able to damage the parts would be minimized. It was determined that while other options might offer a more dramatic demonstration of technology, the IR Communication was the most practical solution. Paired with a wireless communication, it is expected that all of the functionality desired will be possible.

3.2.2.2 IR Transmitter

IR Communication is widely used in technology today, most commonly in remote controls for household items. The technology typically uses pulse width modulation riding on a carrier signal to transmit data by line of sight from and infrared led to an infrared receiver, paired to the same wavelength and carrier frequency. For the purposes of the project it is necessary to use a high power LED to maximize performance. For most do-it-yourself lazer-tag builds, the LED of choice is the TSAL6100 by Vishay. It is known for its high reliability, high radiant power, and has an angle of half intensity of $\pm 10^\circ$.

The LED will be housed in a tube and tests will determine if the game play necessitates a lens component. The lens is used to focus the IR light, increasing the range at which the receiver can be triggered. Play testing will be required to determine how focused the beam needs to be. In contrast to a normal lazer-tag game, the lazer kart project will most likely require a shorter range but wider beam angle, due to the riders not having fine control over the aiming. The height of the receiver in relation to the transmitter will also have to be taken into account.

3.2.2.3 IR Receiver

The infrared receiver is designed to detect the signal produced by the IR transmitter. Interference from other light sources is an issue when selecting the receiver. In choosing a receiver it is necessary to pair it to the transmitter and function required for the design. For the purpose of the project, the Vishay TSOP4856 module was chosen. It contains a photo detector and preamplifier, along with an internal band pass filter so that we can use Pulse Width Modulation for our communication. The 56 kHz variant was chosen because it matches well with the TSAL6100. For PWM communication the receiver recommends a burst length ≥ 10 cycles/burst. The TSAL6100 produces a 940nm wavelength, which translates to a frequency of ≈ 1.06 MHz, or approximately 19 cycles per burst using a 56kHz carrier, well above the threshold recommended. The block

diagram for the TSOP4856 taken from the Vishay data sheet is shown in Fig 3.2.2.1.

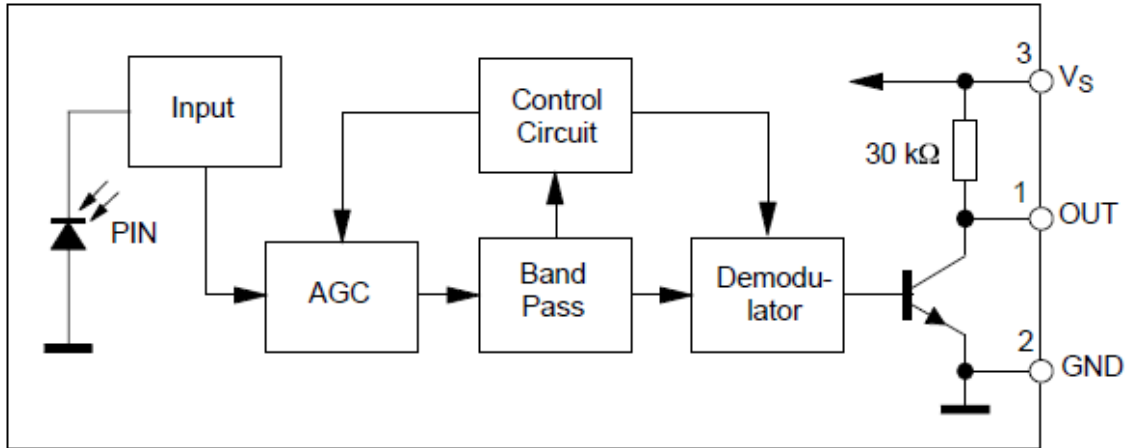

Fig 3.2.2.1

3.2.2.4 Pulse Width Modulation

Now that the components have been chosen, it is necessary to devise a method of delivering the data between them. Pulse Width Modulation (PWM) is typically how this is done. Pulse Width Modulation is an easy way to transmit binary data through IR communications. For instance, by creating a signal of pulses, for a "0" the carrier signal is on for $600\mu\text{s}$ and for a "1" the carrier signal is on for $1200\mu\text{s}$. For basic functionality, the karts now have a binary way to transmit data. If the purpose was to just detect any 56 kHz signal, PWM would not be necessary, however, in order to create a final score at the end of the race we do need to transmit some information. In order to indicate the start of a signal, a header pulse is needed, which should be at least twice the size of the longest pulse, or in the case of the above example. $2400\mu\text{s}$. Real life testing will obviously be needed to fine-tune the sensors. The signal from the receiver is inverted from the input signal from the LED, due to the output being active low as shown in Fig 3.2.2.2.

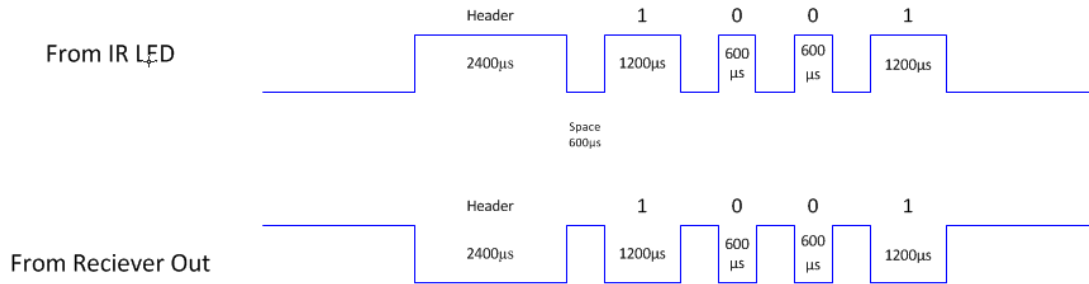

Fig 3.2.2.2

3.2.3 ZigBee Communication

One of the first expansion units that will be considered at the completion of base model testing is the addition of a wireless network designed to allow the karts to communicate with each other and a base unit. This added feature will allow for scorekeeping to determine a race winner, as well as give added controls over the karts for increased safety. With this addition, the ride operator will be able to control individual karts from the vase station, through the link that has been established to the throttle control of the kart.

3.2.3.1 Technology Selection

The requirements for the wireless communication portion of the project are low cost, ease of setup, short range (<200m), high reliability, and low power consumption. The technologies that were considered include the ZigBee, Wi-Fi, Bluetooth, and IR.

Using IR communication would seem to be ideal, as the system is already incorporated onto the lazer kart platform, however, the limitations of this technology to line of sight has serious drawbacks. In order to track and transmit scores to the base unit, a handheld tagger/receiver combo would have to be created that would collect the data from each kart at the end of the race. This would slow down the race process considerably. Also, this would require the use addition of a memory system into the project, which needlessly increases the complexity.

Bluetooth technology does not allow us the range needed, and has a complex set up process and long device connection times.

The Wi-Fi standard was originally considered as the best option, it is a well developed, mature technology, and can handle the range needed for the project. Wi-Fi's major drawbacks are the power consumption and increased set up complexity.

The ZigBee standard allows for the creation of an ad-hoc mesh network, provides the range necessary, and, for the purposes of the project most importantly, has a very low power draw. The low transmission rate, ZigBee's primary deterrent, is not considered an issue for the purposes of the project.

3.2.3.2 The ZigBee Specification

The ZigBee standard, is defined by IEEE 802.15.4. This is used for low data rate wireless personal area networks. The specification was designed with the intent of creating a low power solution for wireless communication, primarily for battery operated control devices, due to the limitations provided by Wi-Fi and Bluetooth. A typical ZigBee network consists of a single Coordinator (C), which is responsible for the establishment of the network, and multiple Routers (R) and End Devices (ZED). The routers can act as end devices and also retransmit data, and end device can only communicate with its parent device, either a router or the coordinator, it cannot relay information from other devices. This is done to allow the end device to operate in a powered down mode, conserving battery power. With the lazer kart system operating without battery, the network will be set up with the coordinator located in the base unit of the track, and each kart will have a router connected in a full mesh network for greatest reliability. Figure 3.2.3.2.1 show the communication used and gives a representation of how the range impacts the network.

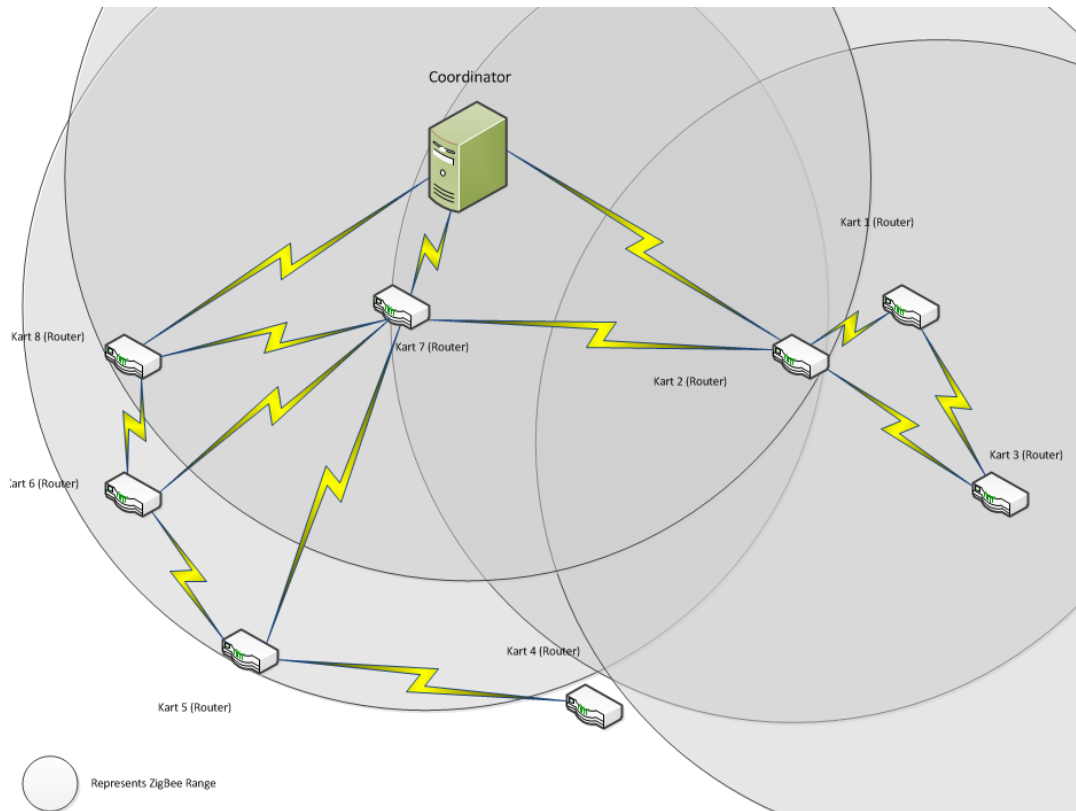

Fig 3.2.3.2.1

3.2.3.3 Adaptation to LazerKart

Using the ZigBee network for the purposes of the project allows for greater control over the karts, and gives an added feature to show to the drivers, end of race scoring. The mesh network will allow for increased ranges, as the karts are spread around the track, it is unlikely that there will be enough separation to create a dead spot in the entire track.

4.0 Hardware and Software Design Details

4.1 Flow Charts

Hardware Block Diagram

The Laser Kart system is based around an MSP430 microcontroller. It will communicate with 4 input devices and 4 LEDs. The inputs are shown below with diamonds and the LEDs are shown below with circles. It will also control a servo via a pulse width modulated signal and the wireless communication system via UART protocol. The power regulator will distribute 3.3V and 5V power to the microcontroller and all of the other systems. Power systems are shown in grey. LEDs are shown in red and green. Photodiode sensors are shown in yellow. Driver inputs are shown in blue, servo systems are purple. Wireless systems are tan.

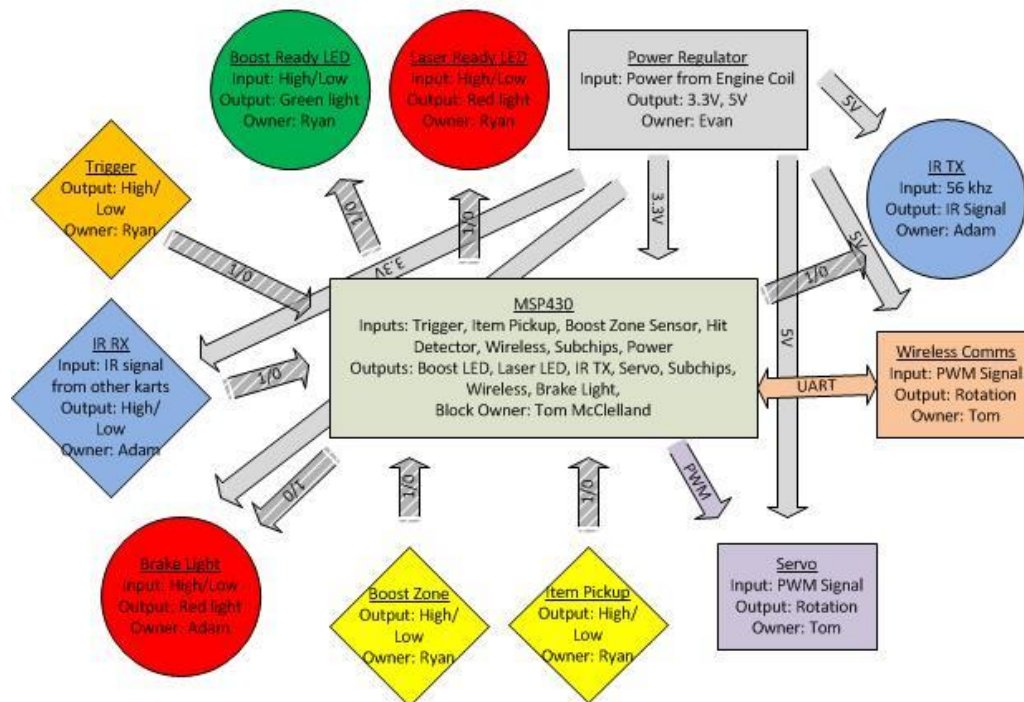

Software Flow Chart

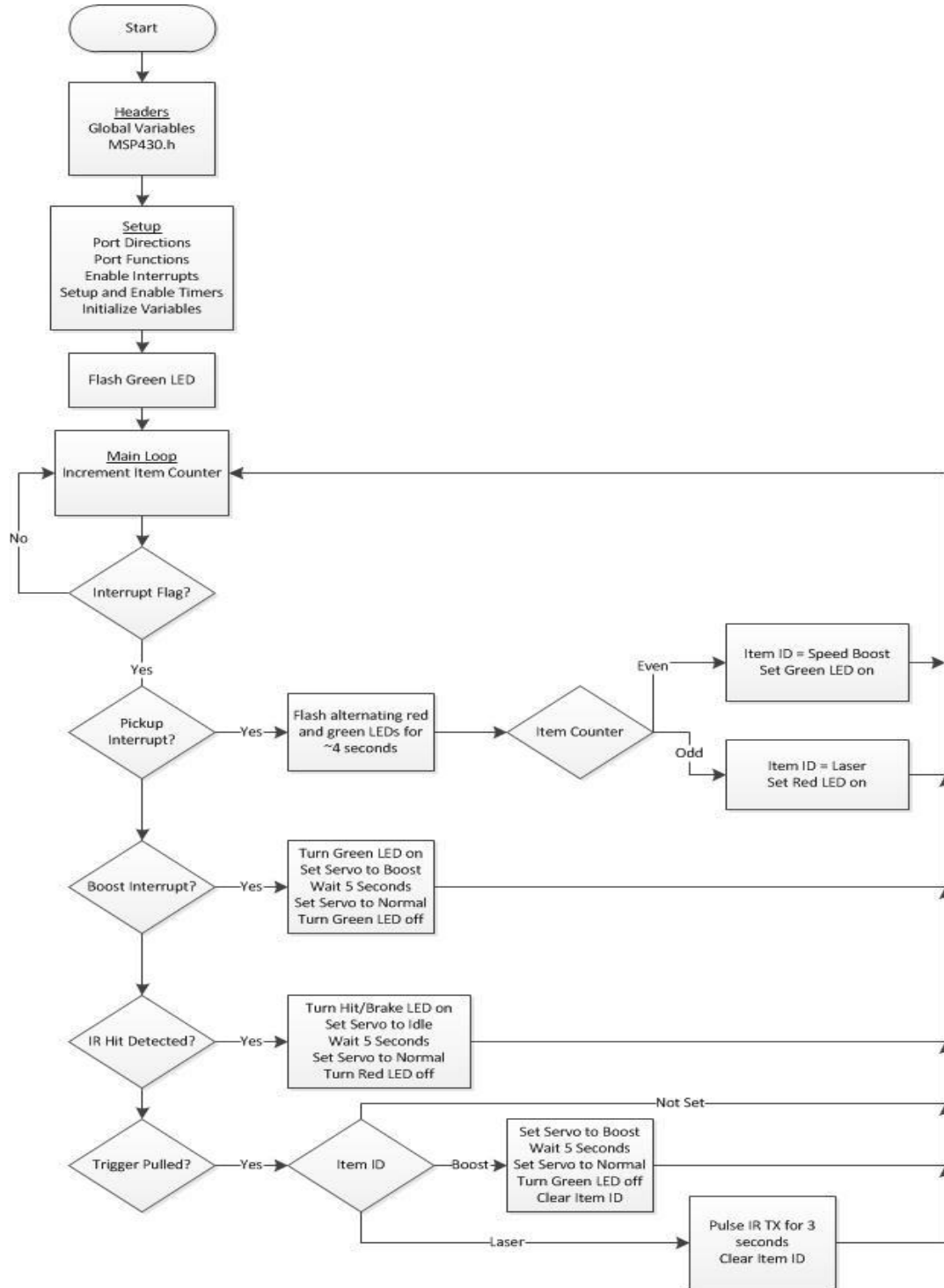

4.2 Power Systems

The main objective of the project's power systems is to provide the peripheral circuits, including the weapons pick up 2-channel op-amp, MSP430 microcontroller, LED lighting, no bumping sensor and warning and IR transmitter and receiver with the appropriate dependable regulated DC voltage and current that is required by each component. In order to provide the DC values necessary, the task is to convert the available AC voltage produced by the Honda GX270 engine to a stable DC value. This will be done using several of the considered rectifier circuits and regulators discussed. Secondly, once the voltage has been converted the system will need to accurately divide the source voltage into the different values needed to power each component using one of the voltage regulators researched thus far, while maintaining the correct maximum and minimum currents in order to ensure that components are operating at the desired power level.

4.2.1 Power Supply Characteristics

In order to begin searching for power systems hardware, it is important to understand the characteristic of the waveform produced by the Honda GX270 AC coil because the signal produced by the coil is what will need to be conditioned. The peak voltage value and frequency of the signal changes based on the RPM rate of the engine. There is a need to measure the range of frequencies and amplitudes of the signal.

It is possible that the output to the Honda engine's AC coil does not have a "clean" sinusoidal output as expected. The signal may rise and fall rapidly or begin to rise and then fall for a short amount of time or any other unexpected signal characteristics produced by the coil. In this case the rectifier circuit will need to be adjusted as necessary in order to accommodate various signals. For example, if the signal rises and falls quickly similar to that of an impulse signal, additional capacitors can be used to harness the rapid changes in voltage. There is also the option of adding inductors to the circuit in order to store a magnetic field while the signal quickly drops to zero so that the ripple voltage can still be obtained.

For now and for the sake of research, obtaining usable values from the GX270 is necessary. A quick and easy way to measure the signal is by measuring the range of RMS values produced by the coil. When idle, the engine is running at about 1,200 RPM or about 20Hz. At this frequency the voltage of the coil is measured and produces an RMS value of about 6.4V. This RMS value will be

used to determine the minimum peak voltage. The RMS value of 6.4V can be multiplied by the square root of 2 or about 1.41 to get a value of about 9.0V peak, which is the peak value for the AC signal produced by the coil when idle. This procedure will be repeated to determine the maximum RMS value on the coil while the throttle on the Honda GX270 is all the way open. While the throttle is all the way open, the motor runs at about 3,200 RPM or at about 53.3Hz and has an RMS value of around 24V. Again the maximum RMS value of 24V is multiplied by 1.41 yielding a value of 33.8Vpeak or 67.7Vpp. The 6.4V-24V RMS, 9.0-33.8Vpeak and the 18-67.7Vpp are the values that will be considered when selecting the converters maximum and minimum input voltage requirements as well as the value used for the initial simulations run using LTspice.

4.2.2 Rectifiers

One option would be to use an ideal rectifier. This design requires the use of an op-amp in order to eliminate the turn on voltage loss through the diodes but would require a DC voltage to power the op-amp which will not be available until after the AC voltage is converted to DC. The design could include the ideal op-amp through the use of a battery but this would be an additional cost for each go kart as well as additional maintenance to charge the batteries after each use making this approach an undesirable solution. This option will only be considered if the loss of the turn on voltage across the diodes does cause issues, in this case the use of a step-up transformer would be used for the systems that require higher voltage since those systems will be the ones that will not receive the appropriate voltage when the engine is at idle. The use of batteries is further discussed in a later section.

Another option to obtaining a DC voltage from the coil would be the use of a half-wave rectifier. This design is very simple design and would have a very low cost since it only uses one capacitor, a resistor and a single diode. The down side to this design is that the output signal has a wide range of values with comparison to other more effective circuit designs. The wide range of output voltage would require the regulators to work with less efficiency and likely heat up which could potentially lead to premature failure.

The most efficient and relatively low cost option to be considered for the power systems AC-to-DC converter is to build a full-wave bridge rectifier using four 1N4148 diodes to convert the sinusoidal waveform produced by the coil using both the positive and negative values as part of the output, unlike the half-wave rectifier. A rectifier that uses four Schottky diodes will also be designed to compare with the results with those obtained using the 1N4148 diodes. The full-wave rectifier will then be in parallel with multiple 4,700 μ F 50V, radial coupling capacitor to flatten out the positive rectified wave to a rippled DC value with as minimal ripple voltage as possible.

Once the ripple voltage is obtained, the “high” node would be the input to each of the regulators used for any of the peripheral systems and the “low” node would be the universal ground for the rest of the system. To allow easy access to the “low” ground node, a rail will be around the PCB designated specifically for all of the subsystems to use as ground.

4.2.3 Simulations

The full-wave bridge rectifier has been simulated giving a rippled DC output waveform seen in Figure 4.2.3.1. A load resistance of $R_L=1k\Omega$ and a 20Hz 9Vp input signal (blue) was used and referenced to ground not “low”. It should be noted that this input is what is expected to be produced while slightly above idle. As stated before the input signals frequency and magnitude will change along with the internal resistance of each regulator as well as the load on each of the regulators themselves; so this simulation is only one of the many conditions that the system will experience. To show consistency the simulated circuit’s stimuli is a signal that would mimic the conditions expected to be produced by the coil when the throttle is all the way open as seen in Figure 4.2.3.2. Keep in mind, that the input will increase and decrease to all the possible values between 9.0V and 33.8V many times throughout one game of LazerKarts.

For the idle simulation the peak-to-peak value of the ripple voltage was measured at about 60mV which is small enough to work as a sufficient input to the voltage regulators for each system. The maximum change in frequency is only about 30Hz so there is no need for additional coupling capacitors. The maximum change between idle and full-throttle peak voltage is approximately 24V which will be an important factor when choosing regulators since they are listed and categorized based on maximum and minimum input voltage. For the fully open throttle simulation in Figure 4.2.3.2 the peak-to-peak ripple voltage actually dropped to around 53mV which means that the output to the rectifier is even more stable at higher frequencies.

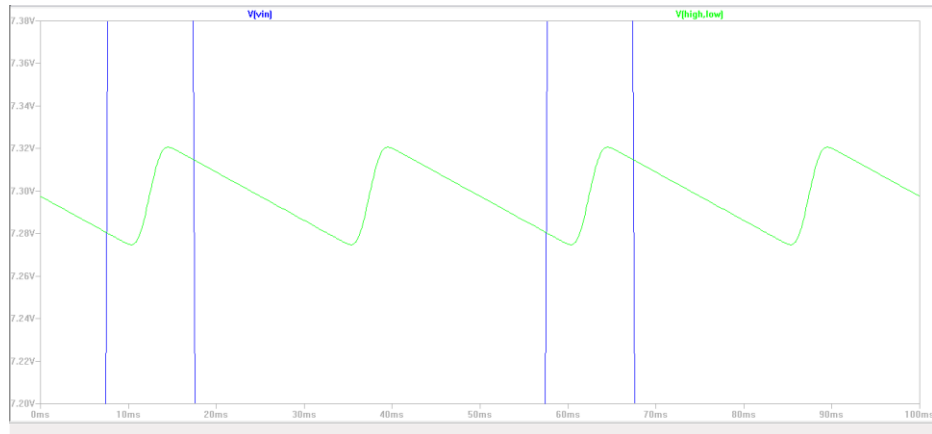

Figure 4.2.3.1 Idle Simulation for full-wave rectifier $V_{in} = 9V_p$ a $f = 20$ Hz, “high”

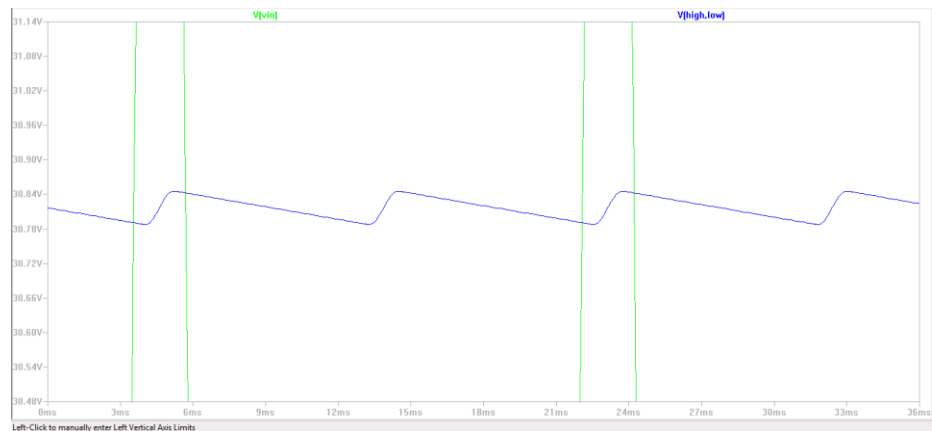

Figure 4.2.3.2 Fully open throttle simulation $V_{in} = 33V_p$ $f = 54$ Hz “high”

4.2.4 Regulators

Once the power supply has been converted to a stable DC signal, the next goal is to condition the ripple voltage with the use of regulators so that the peripheral systems are connected to a pure DC value. The max/min voltage values needed for each of the peripherals are shown in Table 4.2.4.1 along with the amperage needed. When designing a regulator circuit the goal will be try to do so based on these values or select a regulator that can output a fixed value that is midway between the max/min values seen in the table. It is important to choose regulators that are low in cost but meet the requirements of the systems.

The first system to be considered is the MSP 430 G2553. A sufficient regulator for the MSP430 is the LT3008 Series - $3\mu A$ IQ, 20mA, 45V Low Dropout Linear Regulators. According to the datasheet found at the LT website (LT3008) this regulator has the following features

- Input Voltage Range: 2.0V to 45V

- Output Current: 20mA
- Dropout Voltage: 300mV
- Current Limit Protection
- Thermal Limit Protection
- Feedback Protection

The input range on this regulator easily covers the range of DC values at the output of the rectifier while at idle all the way through the values for the fully open throttle. It provides more than enough power for the MSP430. Additionally, it has no need for feedback protection which is key when the frequency and amplitude of the coil are going from high to low or when the throttle gets cut to idle after being hit by an opponent.

The circuit in Figure 4.2.4.2 is the one used to simulate the LT3008. The input pin was connected to the output of the rectifier. The output pin has a load resistance 'RLMSP' that is approximately the operating resistance of the microcontroller. Next we run a simulation of the circuit using the LT3008 and plot the output across the RLMSP resistor. The output waveform can be seen in Figure 4.2.4.3. The output of this regulator is very accurate with only a variation in voltage of about 196 μ V. This variation is well within the tolerance of the MSP430 and provides the 3.3 volts as well as the 250 μ A required to power it. The power supply for the MSP430 is only taking into consideration the amount of power necessary for the MSP430 to run as a standalone unit. It should be noted that while the MSP 430 is performing a function such as activating the break light or sending power to the servo motor to cut the throttle, it will be drawing much higher amounts of current than it will when in standby mode

Next consider the weapons pick up system which uses the 2-channel op-amp to amplify the voltage received by the phototransistor. As seen in Table 4.2.4.1 this requires between 9 and 15 volts. Since this system requires a higher voltage than the others it is likely that we will have to use a transformer in order to step up the voltage output of the rectifier so that even when the motor is cut to idle position and the output of the rectifier drops below 9V this system will still be connected to a sufficient power supply that is above the minimum required voltage of 9V. One solution to this issue may be to use a different op-amp with a lower input voltage requirement. This is further discussed in the weapons pick up portion of the report. The possibility of a step up transformer will only be implemented after testing proves it necessary. For now the choice of a regulator for the weapons pick up and simulations will omit these details.

A possible candidate for the weapons pick up regulator is the LT3014 - 20mA Low Dropout Micropower Linear Regulator. According to the datasheet this regulator has the following key features (LT3014).

- Wide Input Voltage Range: 3V to 80V

- Low Dropout Voltage: 350mV
- No Protection Diodes Needed
- Adjustable Output from 1.22V to 60V
- No Reverse Current Flow from Output

The LT3014 meets all the requirements of the weapons pick up system. Most of all it has the option to adjust the regulated output voltage which will be useful when testing different op-amps with different voltage value requirements to power them since we will be able to change the output by simply choosing different ADJ pin resistors. This regulator circuit and simulation results can be seen in Figure 4.2.4.4 and Figure 4.2.4.5 respectively. The input to the rectifier was chosen to be the idle throttle position to simulate the worst case scenario (low supply voltage). The load resistance RLWP was chosen to be 3.3k so as to give a load current requirement 2.8mA.

The last regulator to consider is the one that will be used to power the IR TX/RX module as well as the other peripheral modules requiring a 5V DC value such as the servo motor. Since this regulator need to deliver much higher currents than those used for the weapons/boost pickup and MSP430 regulators, it important to choose one that has a higher max current output. One regulator that seems to meet the requirements of these modules is the LT1086 - 1.5A Low Dropout Positive Regulator. According to the data sheet found at the LT website this regulator has the following relevant features (LT1086).

- 3-Terminal
- Output Current of 1.5A
- Guaranteed Dropout Voltage at Multiple Current Levels
- Line Regulation: 0.015%
- Load Regulation: 0.1%
- 100% Thermal Limit Functional Test
- Ripple Rejection >75dB
- Available in 3-Pin TO-220 and 3-Pin DD Package

The circuit configuration and a simulation of the output, with the rectified ripple voltage as an input, using the LT1086-5 for the IR Tx/Rx and other modules needing 5V DC, can be seen in Figure 4.2.4.6 and 4.2.4.7 respectively. The output is a very steady 5V with only a 96µV peak-to-peak.

System	MSP 430	2-channel op-amp	IR Tx/Rx
Vin max	3.6V	15V	5V
Vin min	1.8V	5V	4V
Max Current	240µA	2.8mA	1A

Table 4.2.4.1 Regulated values required for each system

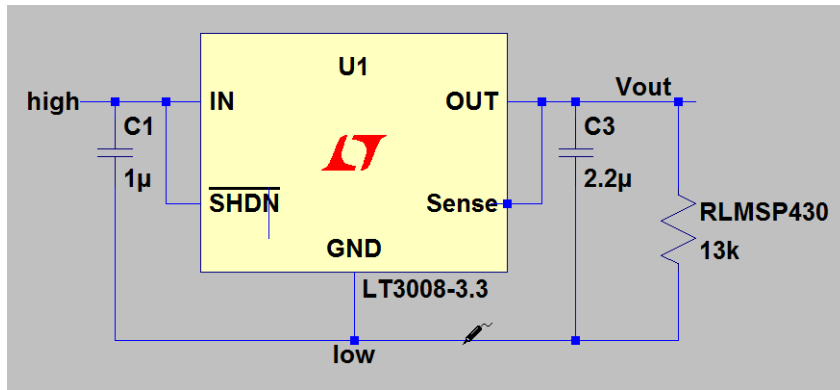

Figure 4.2.4.2 LDO regulator circuit for MSP430G2553

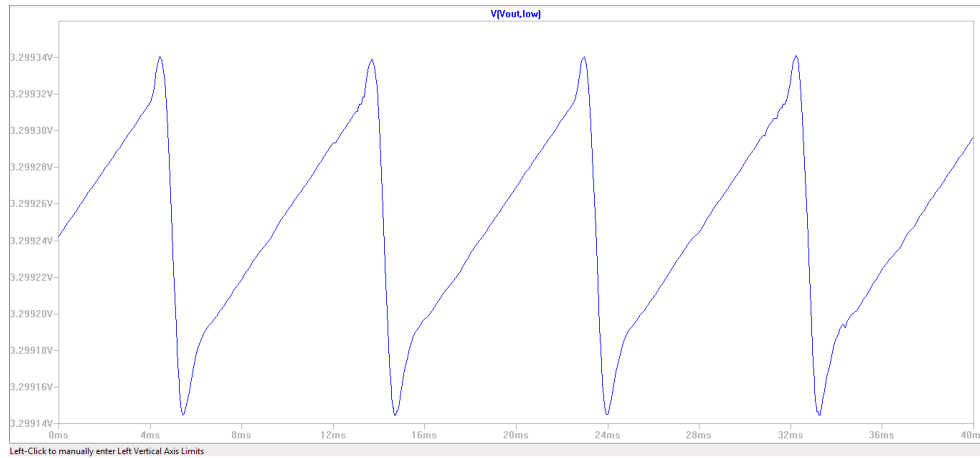

Figure 4.2.4.3 Vout of 3.3V fixed Regulator for MSP430G2553

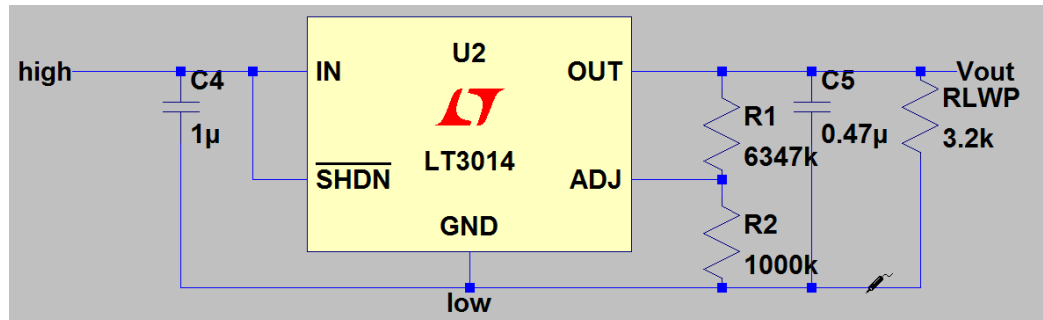

Figure 4.2.4.4 LT3014 Regulator for weapons pickup op-amp

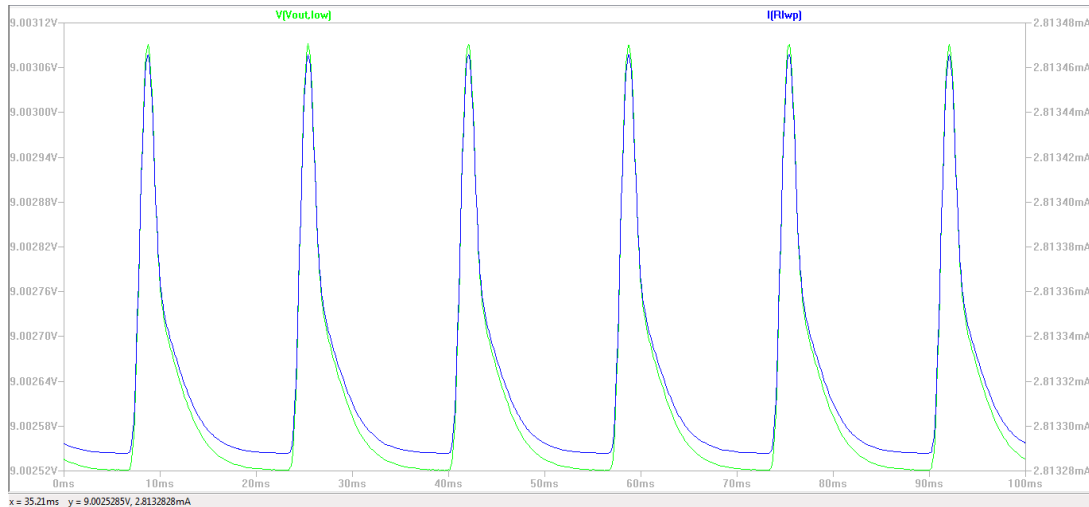

Figure 4.2.4.5 Vout and current RLWP for LT3014 Regulator

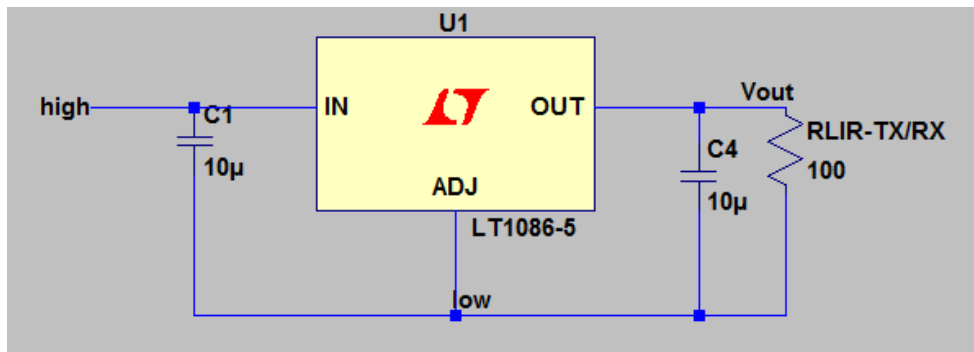

Figure 4.2.4.6 LT1086-5 Regulator for IR Tx/Rx and other components

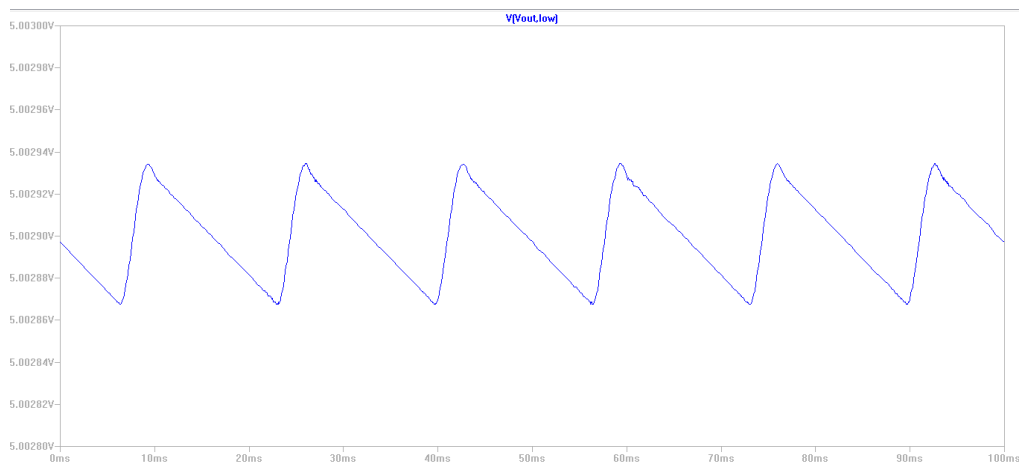

Figure 4.2.4.7 Vout of 5V LT1086-5 fixed Regulator for IR Tx/Rx

4.2.5 Batteries

Although the goal is to power the Karts using the already available AC coil for better long term system sustainability; in the case that the signal produced by the AC coil cannot be converted to DC due to unexpected signal characteristics such as sparkplug interference, it will be necessary to purchase the appropriate batteries to power the system for the demonstration and testing. An advantage to the use of batteries is that the Karts will not require the use of a rectifier circuit or additional PCB design requirements. Since there are several systems requiring power for each Kart there are a number of batteries that can be considered such as the common alkaline, lithium-ion, nickel-metal hydride and nickel-cadmium batteries.

The use of an alkaline battery would be appropriate for the IR Tx/Rx since his system requires higher power. Alkaline batteries are commonly used in electronic devices that require higher power, work well with additional alkaline batteries and have a long shelf life. A downside to alkaline batteries is that the rechargeable versions have a reputation of only being rechargeable a handful of times, making replacement a frequent and costly necessity.

According to one source, the use of rechargeable nickel-metal hydride or nickel-cadmium batteries would be compatible with power requirements of the MSP430 and weapons pickup systems considering they use low power allowing for a minimal amount of recharging. The drawback to these batteries is that they do tend to discharge themselves while not in use and are more costly than alkaline batteries (Nickel Metal Hydride).

Lithium-ion batteries seem to be the most promising alternative solution to the AC coil for means of powering the systems. As stated by one online article, the lithium batteries are slightly more expensive but have a much higher energy density than nickel-metal hydride or alkaline batteries which would allow nearly all the systems on the Kart to be powered by only one or two batteries. Li-ion batteries require much less maintenance which is ideal for the staff at Fun Spot. These batteries have much less self-discharge when not in use and are less impacted by memory (Is Lithium-ion the Ideal Battery).

There are several optional modules such as the 8 x 8 LED displays, programmable LED strips, audio components, additional microcontrollers and ZigBee network that may be added to this list of devices connected to the power system. There are also some components such as the break light and servo motor that will require a 5V line. Conveniently, these modules will use either a 3.3V or 5V operating voltage so it is possible to integrate them to the already existing power system. A circuit diagram can be seen in Figure 4.2.5.1 to

illustrate the core modules that will be connected to the rectifier. Other components will either use the same voltage or are not part of the core system.

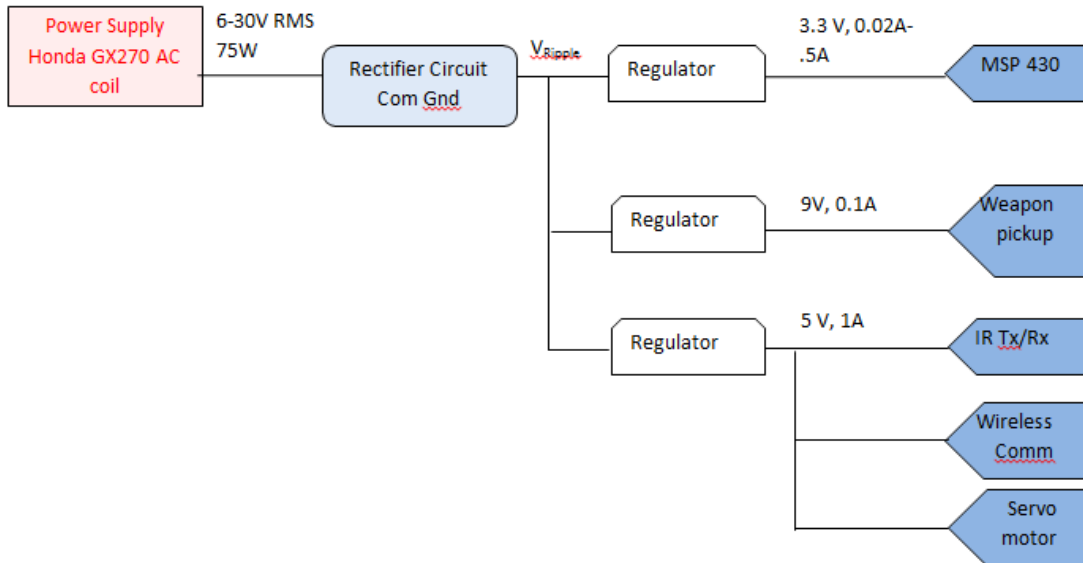

Figure 4.2.5.1 Circuit Diagram of Core Power System.

4.3 Microcontroller

The microcontroller will be the brain of this entire project. It follows that its selection is one of the most important first steps. Here, we outline the microcontroller selection process, detail the chosen microcontroller, discuss required and desired technologies and capabilities, and discuss the printed circuit board it and various other components will be mounted on.

4.3.1 Requirements

The first consideration for the selection of the microcontroller is the number of input and output pins available. The finished project will incorporate several different sensors, user controls, and devices. The microcontroller will at a minimum need to read from the item pickup sensor, the driver's trigger, the IR receivers, and a reset switch. Optionally, there may be the need to read from

communication ports such as UART and I2C as well as analog voltages from an accelerometer.

The microcontroller will also need several output pins. It will be required to turn on dedicated pins to control LEDs, the IR “lazer”, brake lights, hit lights, and to control a servo. Additionally, pins may be needed to control more lighting, sound, and communications equipment.

A core feature of the LazerKart system is the ability to electronically and programmatically control the engine. There are three states that the system will need to select from. First is the normal state where the engine speed is completely dependent on the driver's input to the gas pedal. Second, when the kart is “hit” by a “lazer”, the engine will need to be forced to idle for a short period of time. Finally, when a “boost” is activated, the engine will need to be allowed to briefly run at higher power than is normally allowed. As discussed later in this paper (Section 4.7), the Honda motors on these karts are equipped with a governor that allows for engine power modification. When rotated clockwise, the engine throttle is set to the idle position. When rotated counterclockwise, the engine throttle is opened further than normal. This arrangement lends itself to being controlled by a servo attached to the governor with thin cables and springs. Servos are controlled with PWM (Pulse Width Modulation) with a standard period of 20 milliseconds and pulses lasting from 600 microseconds to 2400 microseconds with 1500 microseconds commanding a neutral setting. Therefore, a core requirement of our microcontroller is the ability to output a reliable pulse width modulation signal.

As previously mentioned, there are several core and optional functions the Lazer Kart system will have to perform. As such, expandability of the microcontroller is very desirable. The chosen microcontroller should be able to communicate with a second microcontroller as well as multiple other devices and subsystems. The I2C protocol is an excellent method of this type of communication so support for I2C is a required feature.

One of the most exciting optional features of the Lazer Kart system is the ability for communication and control through a wireless channel with other karts as well as a base station. There are several available methods for this type of communication, but most of the more popular ones use modules that interface via UART communications. Therefore, our microcontroller should have UART support.

This project is being developed from scratch and is heavily software based. Looking ahead, we are anticipating going through several versions of software for our microcontroller. We will be rewriting our code each time a feature is added, as well as during testing as the inevitable bugs are discovered and worked through. Each version of the software will need to be developed, tested, debugged, and flashed to the microcontroller. Because we anticipate going

through this process several times, it is important that our chosen microcontroller is supported by a simple, reliable, robust, easy to use programmer, debugger, and development environment.

Because the final goal with this project is a full track of 8-10 Lazer Karts, it is important to keep the total price of the build as low as possible. The price of the microcontroller should be under \$5 per unit.

4.3.2 Selection Criteria

To summarize the previous section, our microcontroller must have:

- Minimum of 16 General Purpose I/O pins
- I2C Support
- UART Support
- Programmable Timers able to support PWM
- Analog to Digital Conversion ability
- Excellent Manufacturer Support
- Easy to use programmer/ debugger
- Low Cost, Readily Available

4.3.3 Selection Process

The microcontroller market is dominated by a few major companies. These include Texas Instruments, Microchip Technology, and Atmel. All three of these companies manufacture a wide variety of microcontrollers that vary widely in price, performance, pins, and features. When narrowing down the choices, the first decision that was made was what package style microcontroller should be used. The simplest choice is a DIP package. These are easiest to solder and work with, but are limited to 20 – 28 pins, with 20 being the most common. Next up are *thin-shrink small outline package* microcontrollers. Finally, we have quad flat mount packages either with or without leads. These are available with every feature in the book and can have up to 64 general purpose I/O pins. They can be very powerful and would allow us to do everything we want on one chip. However, for our project we will require the ability to swap microcontrollers in and out of the final circuit for testing and programming purposes, so options like the quad flat package with no leads were not really an option. Zero insertion force sockets are available for these, but they are priced at up to \$100 and are not affordable. Thin-shrink and small outline packages are not as costly, but they need to be soldered in place to work and do not lend themselves to the type of development work we will be doing. That leaves DIP's. Dual In-Line Packages are easier to work with and solder and sockets for them are available for as little as \$0.11. DIP's are very common and are supported by readily available tools. It was decided that although microcontrollers such as the Microchip Technology PIC24F08KL402, TI MSP430F235, or the Atmel AT32UC3B0128 would be great

to have, their form factor was a major drawback. If we could find a suitable microcontroller in 20 pin DIP form, that we would use it.

After deciding on the form factor, the next most important criteria was the programming and debugging hardware. A really powerful chip with lots of amazing features is worthless to us if we can't easily and efficiently development code for it. Atmel offers several customized development boards with built in programmers, but they are priced at up to \$200 and are fairly specialized. Microchip Technology has a product known as the Microstick for 3V PIC24F series microcontrollers. It is a development platform that combines programming and debugging, power regulation, solderable pads for each pin on the chip, and reset button. It is only compatible with Microchip's KL and KA line of microcontrollers, but that isn't an issue because the PIC24F16KL402 meets all of our requirements. The development board retails for \$35 and the PIC24F16KL402 retails for around \$2.58 (depending on quantity purchased). Finally, Texas Instruments offers a similar product called the Launchpad. It is also a development platform that combines programming and debugging, power regulation, and reset button, but it is fitted with male headers for easy connection instead of solderable pads. The Launchpad also has 2 on-board LEDs. The TI launch pad supports their "Value Line" of microcontrollers. This is also acceptable because the TI MSP430G2553 meets all of our requirements. The MSP430G2553 also retails for around \$2.50, but the TI Launchpad is available for only \$5.00. For coding, Microchip Technology is supported by their MPLAB development environment. It offers C and C++ coding and full debugging and is compatible with nearly all of their chips. TI similarly has the Code Composer Studio. It is also a full featured development environment.

These factors narrowed the choice of microcontroller down to the TI MSP430G2553 and the Microchip Technology PIC24F16KL402. While the PIC controller offers more I/O pins than the 430, they both support I2C, and are therefore expandable. Using I2C, our project could be expanded to 2, 3, or more chips, each with 16 IO ports. It would be desirable to demonstrate our team's ability to use I2C, so this is actually a benefit.

TI MSP430G2553IN20

Frequency: 16 MHz
Flash Memory: 16 KB
SRAM: 512 bytes
IO Pins: 2 Ports, 8 Pins/port
Timers: 2x 16 bit Timers
USCI_A: 1 UART
USCI_B: 1 I2C/SPI
ADC: 8 Channels, 10 bit ADC
Package: 20 pin DIP
Price: \$2.79 from Digikey.com

PIC24F16KL402

Frequency: 16 MHz
Flash Memory: 16 KB
SRAM: 1024 bytes
IO Pins: 3 Ports, 8 Pins/port
Timers: 2x 16 bit Timers
USCI_A: 2 UART
USCI_B: 2 I2C/SPI
ADC: 12 Channels, 10 bit ADC
Package: 28 pin DIP
Price: \$2.58 from Digikey.com

4.3.4 MCU Selection

Ultimately the cost of the development tools and our teams existing familiarity with Texas Instruments products led to our decision to select the MSP430G2553 as our microprocessor. Additionally, the engineering and manufacturing industries have been recently pushing for the use of COTS, or Commercial, Off The Shelf, products. We actually had a MSP430G2553 sitting On The Shelf, and so feel that utilizing this part is in keeping with the current industry trends. It is also worth mentioning that Texas Instruments is again sponsoring a college level project design contest and will be supplying free parts and the chance to win large cash prizes to projects that use their products.

4.3.5 MCU Technologies

4.3.5.1 Digital I/O

The microcontroller is the brain of our project, but it will be interacting with several other types of components. Each component is connected to the microcontroller through one or more pins. The pins on the MSP430 are configurable as either input or output pins. This selection is made by setting the bits in the PxDIR register (where x is the Port number) to either 1 or 0. Zero designates the pin as an input pin and 1 designates the pin as an output pin.

Pins configured as Output pins can be written to by the software. Writing a 1 to an output pin tells the microcontroller to pull the pin high (to Vcc) and writing a 0 tells the microcontroller to pull the pin low (to Vgnd). Lazer Kart uses simple output pins to illuminate LEDs.

Other pins are configured as Input pins. These include the pickup sensor, the hit sensor, and the driver's trigger. The simplest is the driver's trigger. It is used to activate the item currently held by the driver. It is a simple switch that will pull the corresponding pin high, which for this project means to 3.3 Volts, the same is Vcc. The microcontroller reads this as a digital 1 and can react accordingly. The pickup sensor and the IR system will be discussed further in their own sections, but they also communicate with the microcontroller by pulling their pins high.

4.3.5.2 Interrupts

Once an input pin is pulled high, there must be an association in the software to that event for anything meaningful to happen. For example, if we wish for a subroutine to be called when the trigger is pulled, then the microcontroller must first know to check on the pin associated with the trigger, and then know to execute some code depending on its state (high or low). One way to do this is called polling. The software contains a line of code to explicitly check the status

of a pin. This is often followed by an if statement. The problem with polling is that it is inefficient to always have the microprocessor checking a pin. Plus, if an event pulls a pin high for a brief time, the microcontroller might miss it because it was doing something else between pin checks. A better way is to use interrupts. An interrupt literally “interrupts” the code being run and immediately executes different code. It then goes back to where it left off and continues as normal. To use interrupts on the MSP430, the software first enables them by writing a 1 to the corresponding bit in the Interrupt Enable register PxIE. Then, the software selects an interrupt type known as edge select. An interrupt can either be triggered by a rising edge from a 0 to 1 transition or a falling edge from a 1 to zero transition. This is selected by writing a 1 or 0 to the appropriate bit of the PxIES register. Once an interrupt has been triggered, the code will immediately go to an Interrupt Service Routine. The Interrupt Service Routine is like a function that is called by an Interrupt and returns to the code when it's completed. Lazer Kart uses rising edge interrupts to call routines for trigger presses, item pickups, and being hit by another driver's “lazer”.

4.3.5.3 Pulse Width Modulation

Servo motors are controlled with a Pulse Width Modulation type of signal. The Lazer Kart systems use a servo to control the engine governor, so our microcontroller must be able to output a pulse width modulation signal. The MSP430 is able to output such a signal by using an integrated Timer. When this on board Timer is engaged, each clock cycle, the microcontroller will, in addition to any other code being processed, increment the Timer Register. The timer can also be configured in other modes, such as decrementing the Timer Register, but Lazer Kart uses Up Mode, so it will be the only one discussed here.

Once engaged, the time will increment the timer register each clock cycle until reaching a set value called TACCR0. Upon reaching TACCR0, the timer will reset to 0x0000h. This is visually explained in the MSP430G2553 User's Guide with the following figure 4.3.5.3.1:

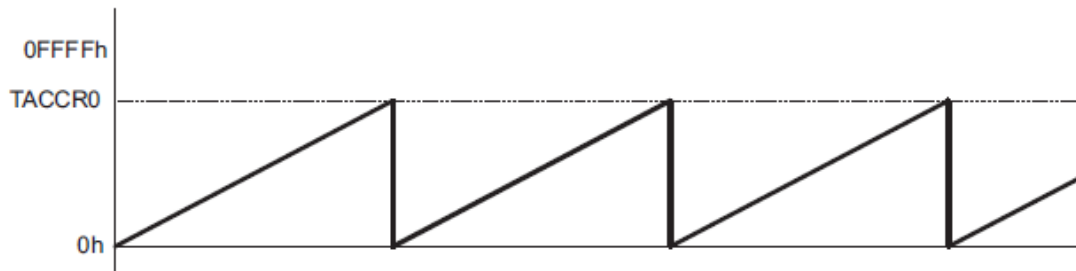

Figure 4.3.5.3.1 Diagram For MSP430 Timers
Reprinted from the User's Guide as allowed by TI

Our servo requires a Pulse Width of 1.5 (+- 0.9) milliseconds every 20 milliseconds. Given a clock rate of 1 MHz, setting TACCR0 to 20000, we can use the Timer as our 20 millisecond period. Now, we need a way to set the output pin to 1 for just the first 1500 clock cycles. This can be done by using Output Mode 7 (Reset/Set) and another value known as TACCR1. When the Timer Register reaches TACCR1, the Output Pin associated with the Timer will Reset, or go to zero. When the Timer Register reaches TACCR0, the Output Pin associated with the Timer will Set, or go to 1. This is again visually explained in the MSP430G2553 User's Guide as shown in Figure 4.3.5.3.2 below:

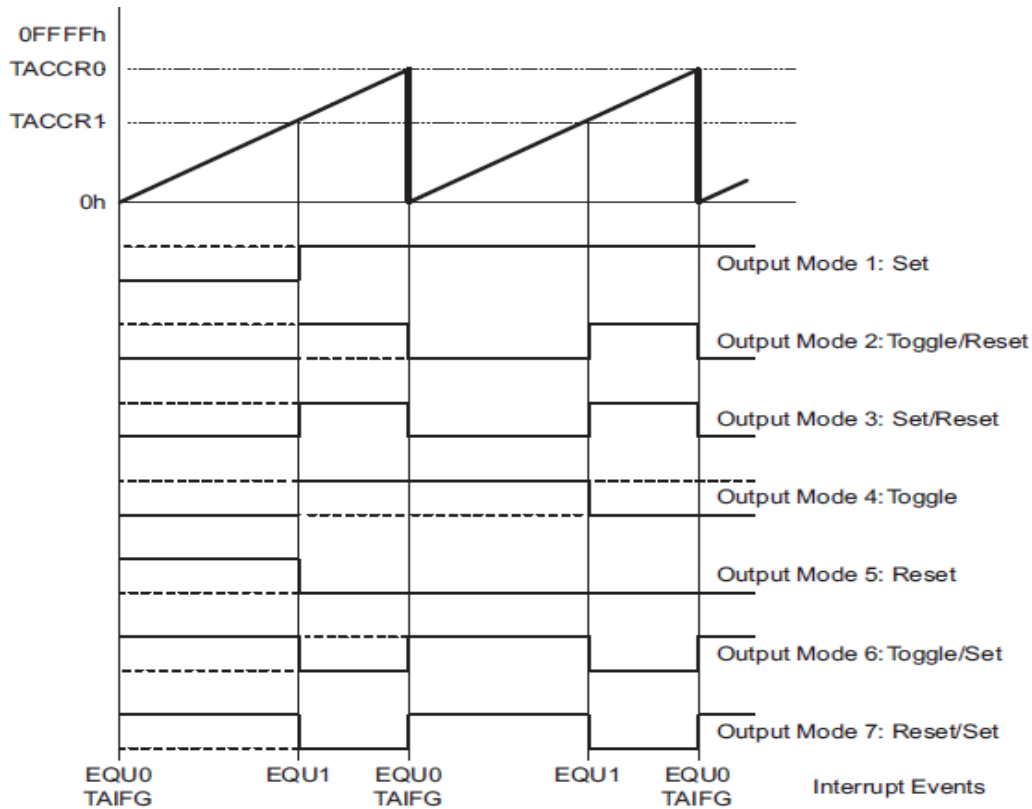

Figure 4.3.5.3.2 Output Modes for the MSP430 Timers
 Reprinted from the User's Guide as allowed by TI

As you can see from the last waveform on the above graph, the MSP430 can in this way generate a pulsed signal equal to 1 for the first 1.5 milliseconds of period 20 milliseconds. The servo can then be controlled simply by changing the value of TACCR1. The servo operates based on a center position with rotations of +- 90 degrees possible. The center position is commanded with a pulse of 1.5 ms or 1500 cycles for TACCR1. The Servo maps +90 degrees to 2.4 ms and -90 degrees to .6 μ s. Therefore, we can use the formula $1.5 + (\text{angle desired off of center} * .00001 \text{ seconds}) = \text{Pulse Width in milliseconds}$. Then the pulse time is multiplied by 1000000 cycles/ second to get the number cycles for each pulse.

The Lazer Kart will be using +- 45 degrees, which equals 1050 cycles and 1950 cycles.

4.3.5.4 I²C

While a single MSP430G2553 only has 16 general purpose input/output pins, this project needs to be expandable so that other optional modules can be added. Modules such as the sound board and extra lighting require more pins than a single 2553 can provide. The solution is to use multiple MSP430's networked together using the I2C protocol. I2C stands for Inter-Integrated Circuit. It is a two bus protocol where there is one controller that functions as the "master" device and one or more "slave" devices. Each MSP430 on the network will utilize 2 pins for I2C communication, one for the clock signal and one for data. All of the clock pins will be connected to the same bus.

The Master MSP430 generates the clock signal and all of the other microcontrollers will use the Master clock to keep in time. Additionally, all of the data pins on the other MSP430's will be connected to the same data bus. This allows the master to communicate with any slave controller by first sending it's address, followed by a command. Optional modules can be added with their own microcontroller and set of commands. These slave microcontrollers could drive a LED matrix display, control accessory lighting, implement a basic audio system, or control bumping and safety sensors. Each of these subsystems and their associated microcontrollers will be discussed in their own section of this report. This section will continue discussing the functionality of the master MSP430.

4.3.5.5 UART

Each kart racing around the track will have its own Lazer Kart system installed. Each system has the ability to directly control that kart's engine. For safety reasons, it would be useful for a ride attendant to be able to wirelessly control a given kart. Details of the wireless communication system will be covered in its own section of this report, but one important detail is that the wireless communications system will interface with the microcontroller using the MSP430's UART port. The ZigBee board will accept a stream of UART data from the MSP430 and transmit it to the ZigBee on another kart. The receiving ZigBee will then output the same UART data into the main MSP430 controlling that receiving kart. Each kart can also be sent commands from a base station. Commands will include All Karts Stop, Kart X Stop, Kart X Slow Down, and Kart X Play Sound File N. In this way, the operator can control all the karts, stop an individual kart, or send an audio warning to a specific kart about bumping or reckless driving.

4.3.5.6 MSP430 Pin Diagram

The MSP430G2553IN20 is a 20 pin DIP package microcontroller. The following Pin Diagram (Figure 4.3.5.6.1) from the MSP430's Datasheet shows the location and function of each pin on the MSP430.

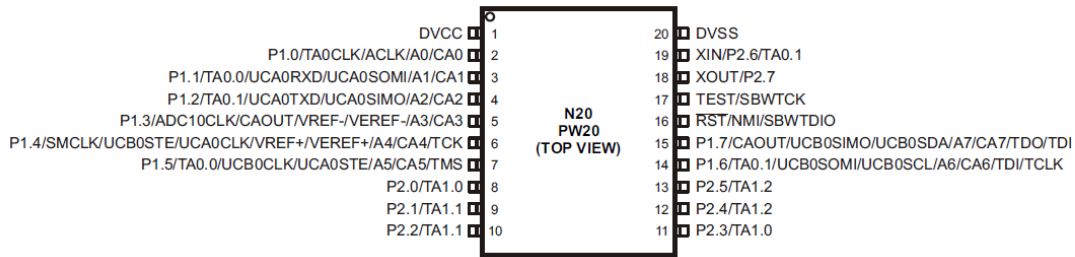

Figure 4.3.5.6.1 Pin Layout of MSP430G2553IN20
Reprinted from the Datasheet as allowed by TI

As you can see, there are 10 pins on each side. Our master MSP430 will be using these pins as a combination of digital inputs, digital outputs, PWM outputs, and special functions.

<u>Input Pins</u>	<u>Output Pins</u>	<u>Special Pins</u>
1.0 Boost Pad Detect	2.0 Boost Ready Light	1.1 UART RX
1.3 Item Pickup	2.1 Lazer Ready Light	1.2 UART TX
1.4 IR Receiver	2.2 Hit and Brake Lights	2.6/2.7 Crystal Oscillator
1.5 Trigger for Items	2.4 PWM Servo Control	1.7 I2C Clock
	2.3 IR Transmitter	1.6 I2C Data

These functions are summarized below.

<u>Function</u>	<u>PIN</u>	<u>PIN</u>	<u>Function</u>
3.3 V	VCC	Vss	Ground
Boost Pad Detect	P1.0	P2.6	OPEN
(Reserved for Xbee)	P1.1 (UART RX)	P2.7	OPEN
(Reserved for Xbee)	P1.2 (UART TX)	TEST	NA
Item Pickup	P1.3	RESET	Reset Button
Hit Detector	P1.4	P1.7 (I2C: CLK)	(Reserved for I2C)
Trigger	P1.5	P1.6 (I2C: Data)	(Reserved for I2C)
Boost Ready Light	P2.0	P2.5	OPEN
Laser Ready Light	P2.1	P2.4	Servo PWM
Hit/ Brake Light	P2.2	P2.3	Fire Front

4.3.5.6.2 The Printed Circuit Board

To simplify construction and installation of the Lazer Kart system, many of the core components will be grouped together on a printed circuit board. At the center of the board will be the microcontroller, surrounded by all of the required electronic components for the Lazer Kart system. The only items that will not be mounted

on the printed circuit board will be the IR transmitter, IR receiver, pickup sensor, and the driver's trigger and item indicator panel. These sub-systems will be discussed in detail in their own section of this report.

4.3.5.7 Components

Before the microcontroller can be powered, the power sub-system must supply a regulated 3.3 volt DC source. As such, the printed circuit board will require mounting locations for the following:

4 Rectifier diodes

1 Rectifier capacitor

3 5 pin regulators, each with 2 capacitors and 2 resistors

One of the 3.3V regulator outputs will go to the Vcc pin on the MSP430. It will also parallel a small LED that will be used as a power indicator light. The other 2 regulators will each route to a wire terminal for use on the servo and item pickup modules.

The microcontroller will be mounted on a 20 pin DIP socket that will be soldered to the printed circuit board. The 4 input pins will be routed to wire terminals for easy connection of the Boost Pad detector, the item pickup detector, the hit detector, and the trigger. The Boost Ready LED, the Lazer Ready LED, and the Servo control can all be driven directly from the microcontroller. These pins will also be traced to wire terminals, but through a current limiting resistor.

Because there will be several LEDs used for the Hit and Brake lights, a 3 pin MOSFET will be used as a switch and mounted next to that pin. The IR transmitter also requires a high current and will so also be controlled indirectly using a MOSFET.

The Reset pin will be wired to Vcc through a normally closed switch.

4.3.5.8 Traces

Many of the traces on our printed circuit board will only be carrying information, not power. That is, they will be operating at 0/3.3V and carrying almost no current. These traces can be quite small. Our chosen PCB manufacture can lay down traces as small as 8 mil, but we will use 10 mil for information traces.

Power traces must be much larger. These will be carrying current for the IR transmitter, brake lights, and the servo. The servo may be drawing up to 1.5 amps during operation and the coil on the kart engine is capable of supplying up to 3 amps. That many amps on such a small trace will cause the temperature to increase drastically. Pushing too much current through too small of a trace will damage the board. As such, power traces must be sized accordingly. Many printed circuit board companies, such as Armistead Technologies, recommend a 30 mil trace for currents up to 3 amps. That size trace will limit the temperature increase to less than 28 C. Therefore, our traces will be 10 mil for information and 30 mil for power.

4.4 PCB Diagram

The PCB will be designed in FreePCB before the Gerber and Drill files are sent to the manufacturer. The Layout is shown below in Figure 4.4.1.

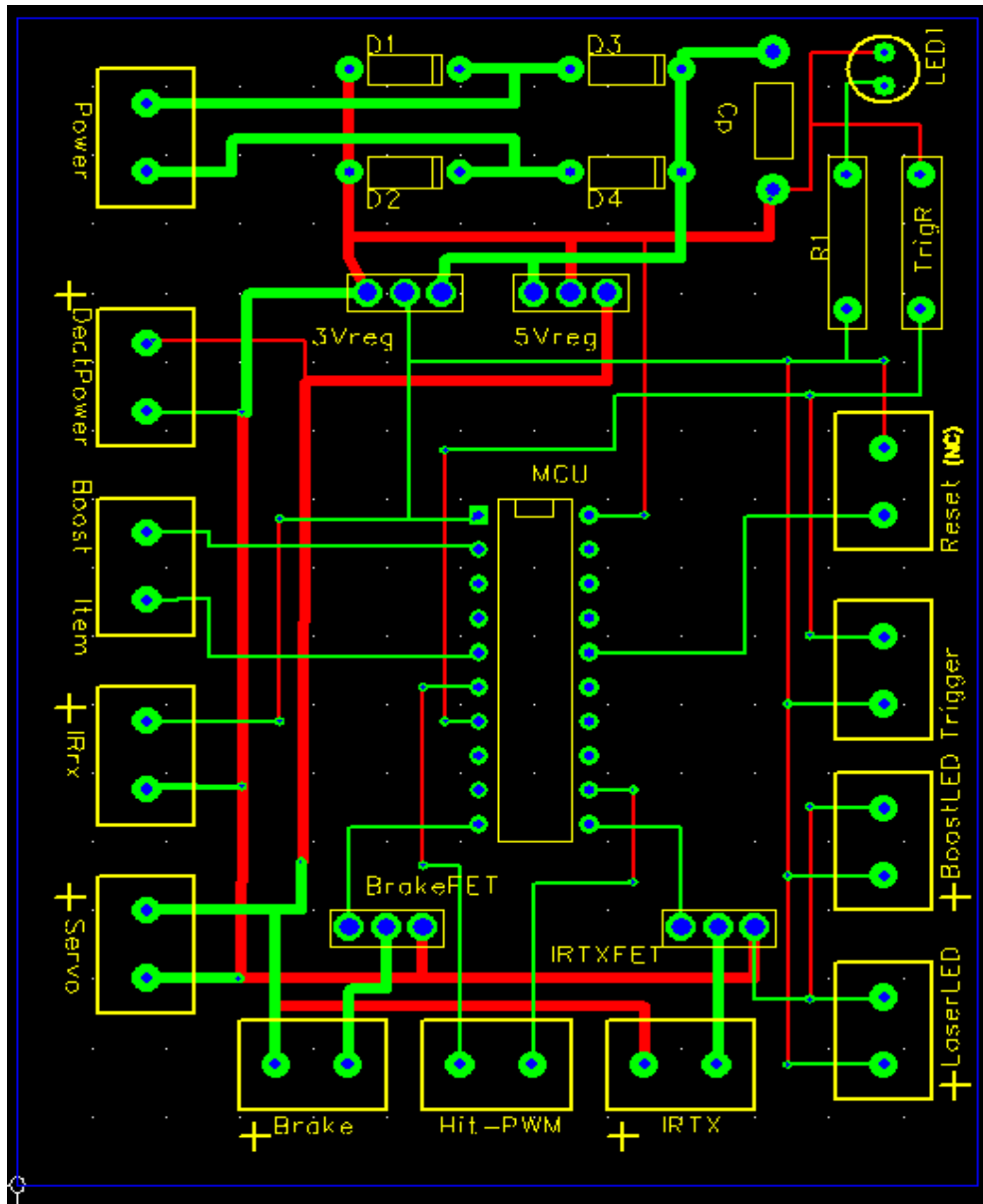

Figure 4.4.1 PCB Layout

4.4.1 Manufacturer

Our finished printed circuit board will be manufactured by BatchPCB.com. Their price is \$2.50 per square inch plus a \$10 setup fee. Our board will measure 2.5 inches by 3.5 inches as shown above for a total of 8.75 square inches at a cost

of \$21.88 + \$10 for a total of \$31.88 for the board. This project could have used a simple prototype board with jumper wires, but this PCB will look much more professional.

4.5 Item Acquisition

One of the key aspects of implementing the LazerKart enhancement system is being able to obtain an item or “power-up” that allows the driver of the kart to gain a better position on the racetrack. In order to do this, the kart must be driven over some sort of marker that the kart can unmistakably sense as a power-up marker. Several different methods were considered to effectively accomplish this task.

4.5.1 Implementation Options

The first method was to have a projector (i.e. Christmas decoration type) located under a bridge or an over pass of the track display an image onto a steady stream mister or fog from a fog machine. The driver would then drive through the mid-air image, while an RFID reader located near the fog machine would read an RFID tag on the kart and activate the power-up algorithm. The image would shut off for a second or two and then regenerate, similar to how the item boxes disappear and reappear in the Mario Kart video games. The inherent problem with this system is the cost and feasibility of the RFID system in addition to the visibility of the projector during daytime operation.

The next method that was considered was embedding small RFID tags on the track and placing the RFID reader on the kart. The RFID tags would be marked by colored tape or paint to be visible. While this method isn't entirely unfeasible, the cost of an RFID reader that could acquire a tag from 4 inches off the ground at a speed of up to 25 mph seemed to be prohibitive for the scale of this senior design project.

The most cost-effective method for power-up acquisition as of yet is the optical sensing method. The concept is simple, an LED, located underneath the kart, shines light down at the ground. When the kart drives over a colored marker, the light from the LED needs to reflect that color back up to an optical sensor which can distinguish that color from the color of the ground and other colors. This implementation was chosen to be incorporated into LazerKart.

4.5.2 Optical Sensor Subsystem

An initial idea was proposed for the optical sensor subsystem to be comprised of photodiodes with colored filters that would react to the colored marker that corresponds with each filter. While doing research about this topic, a Google

search for photodiodes gave results that mentioned the use of LEDs as photodiodes. There were many LEDs on hand and no photodiodes, so the choice was made to see how far an arrangement of different colored LEDs could go as far as accurately differentiating color and whether or not it could be done at all.

A particular source (<http://www.robotroom.com/ReversedLED.html>) showed a picture of a Digital Multi-Meter measurement across the pins of a disconnected LED in a well-lit room. The DMM showed a positive voltage just from the ambient light striking the LED. So at that point a measurement was taken using a 5mm red (680nm) LED and a Tektronix CDM-250 Multi-Meter. In a normally lit room, the LED produced a voltage difference of 90 mV. When the lights went off, the voltage went to 0 volts. The decision was made to put the diode across the input terminals of one channel of a TL084 op-amp and see if it would give an amplified output accordingly to the off and on switching of the ambient room light. The results of that basic test were successful, with the light off, output was the $-V_{cc}$ rail and with the light on, the output was the $+V_{cc}$ rail.

4.5.3 Continued Research and Initial Circuit Design

LEDs are designed to emit light with highest energy at a certain wavelength, however, they happen to also emit smaller and larger wavelength light, but with decreased energy. LEDs are sensitive to light in a similar way, but they respond with the most energy to light that is at a slightly smaller wavelength than the light they were designed to emit. For instance, a green LED might respond more so to bluish green light than to pure green light. So, this must be taken into consideration when testing for color differentiation using LEDs.

Now that it is established that an LED can be effective at sensing ambient light, a circuit needed to be created that would detect and respond to individual color bandwidths and not just white light. To do this, 3 channels of a TL084 op-amp had their input terminals occupied by LEDs of differing color: one red, one green, and one yellow. Each of the outputs had another LED of the corresponding color to its inputs, but anode was connected to ground while cathode was to the output. That way, the output LEDs would turn on when the room light was turned off and vice versa. This was called the "Night-Light" test. With this circuit functioning properly and responding to ambient light, the next step was to add a constant-on white LED to the circuit and shield it from the other LEDs. The point of adding the white LED is that now the test is to scan an object over the white LED so that light reflects off of it and back down to the sensor mode LEDs.

At first, it was thought that a highly reflective material would be the solution to getting the light to the sensors effectively. So, a red bicycle reflector was used as a test as well as red, blue, and green reflective foil paper. When scanning any of these objects over the white light, all of the sensors were tripped. The realization was made that highly reflective material had a glossy coating that exhibits

specular reflection in that all of the incident white light will be reflected down on the sensors, thus the sensors are sensing their portion of the spectrum included in the white light. The solution was to use something that was more diffuse like a brightly colored t-shirt. A red t-shirt was scanned over the white light and only the red output light turned off. This means that the shirt absorbed all frequencies of the white LED except for a region of red frequencies, which were reflected down onto the sensor LEDs, with the red LED having the most responsiveness to that wavelength of light while the other LEDs had no responsiveness. However, if the energy of that red spectrum of light were higher, it could have tripped the other sensors (as we will see later). Another shirt, this time a blue one, was scanned over the white LED, and only the green sensor LED responded. So, this test was a success that gave confidence in the use of LEDs as color sensing elements, however it must be noted that the response times to the light reflected off of the diffuse t-shirt material was slow, in that the shirt would have to be held over the white light for about half of a second before the night-light turned off.

4.5.4 Optimizing LED Sensor Circuit

The initial test circuit was designed to determine if LED color sensing was possible. Now that it has been confirmed to be the case, a more useful circuit needs to be designed that will more closely fulfill the requirements of the LazerKart system. To avoid complicating the power distribution system to offer a +Vcc and a -Vcc power supply, it is required that a single supply op-amp is utilized in the sensing circuit. The TL084 can be used in single supply operation, but at a cost. The low output voltage will be some value above zero volts, while the high output voltage will be some value below the +Vcc rail. The TL084 requires +Vcc to be at least ___ so the decision was made to give it a +Vcc of 9V. At this point, The low output voltage was measured to be ~1.5V and the high output voltage was measured to be ~8.5V. Another single supply op-amp was considered before the discovery of the TL084's single supply mode operation (TI article), but the other op-amp (LM324) had too low of an input resistance compared to the TL084's high impedance JFET inputs to recognize the small voltage difference produce by the sensing LEDs.

This circuit will have a button that will be used as the 'fire' button. It will turn off an indicator LED that gets activated when the sensor op-amp output goes high. To do this, the sensor portion of the circuit will be connected to an SR-latch. The SR latch is created by using one half of a 4001 quad NOR gate. One of the sensor outputs of the op-amp is connected to the 'set' and a small momentary button is connected to 'reset'. Q is connected to the base of a 2222NPN transistor that switches on/off the indicator LED ready light. The sensor LED is to be shrouded in black electrical tape and partnered to the white emitting LED, both of which will be extended via 1-1.5' of wire, so the optical elements are free to move for testing and can be remotely located on the go-kart.

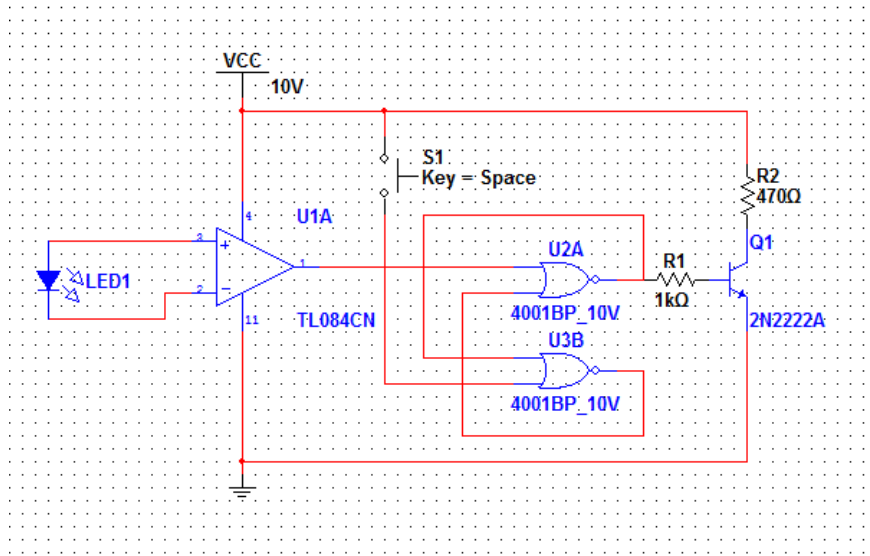

Fig. 4.5.4.1: Optical sensor circuit 1

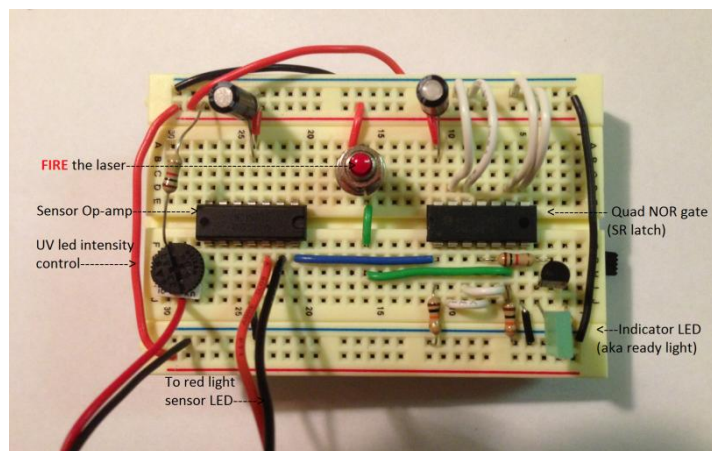

Fig. 4.5.4.2: Optical sensor prototype

The circuit is complete and ready to be put to the test. Before using on the go-kart, the test was run on white carpet, which will have similar reflective properties to the white concrete racetrack that the go-karts will be run on. The lone sensor LED chosen was a green LED. The first test was a total failure, because the white LED is constantly shooting white light at the white carpet which reflects white light that is constantly triggering the sensor. The solution to this was peculiar but very interesting. By replacing the white LED with a UV LED, the spectrum of light cast on the ground only reaches the low blue range, so if the sensor is changed to red, it won't detect the blue-violet light that is continuously reflecting off of the ground. But now, the interesting part is the material used as the item marker. Certain fluorescent colored materials are highly reactive to UV light and emit a reflected light with sufficiently high energy (thus the glowing-under-a-black light effect). Neon poster boards reflect very well under UV light

and were used as a test material. The red LED responded very quickly to the neon poster board that reflected in the magenta/pink wavelengths (fluorescent reddish-orange under white light). It was time to test a second color and see if the system can differentiate between the two.

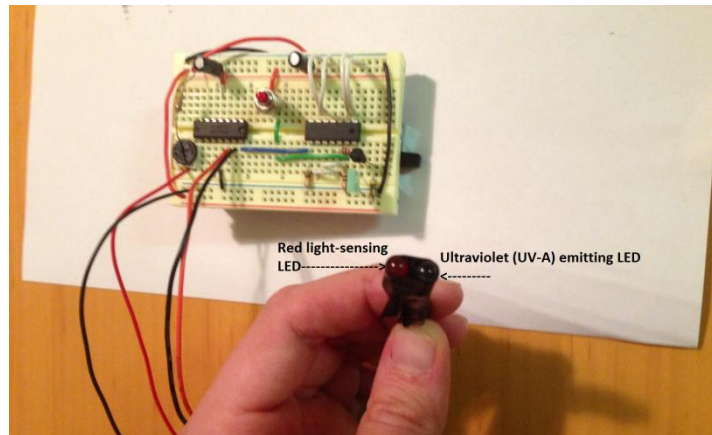

Fig. 4.5.4.3: Emitter and sensor LEDs

Adding a second sensing LED (yellow) and its respective SR latch and indicator LED to the circuit was not difficult. The yellow sensor was tested individually first to observe its responsiveness. It responded very quickly to both the neon green and neon yellow poster-board material. As a side note, a yellow highlighter marked on white paper proved to be highly reactive to UV light and allowed for superior response characteristics in the yellow LED. Now the red LED and the yellow LED were both tested together using the neon reddish-orange poster and the neon green poster. The results were not very promising. While the yellow LED responded to the green poster, the red LED didn't initially respond, but if moved slowly enough over the poster, it would respond. A different (unknown origin) red LED was used and the problem was solved. So, bandwidth characteristics vary between LED manufacturers, and it is unclear if perhaps there is a variation between LEDs of the same production batch from the same manufacturer.

4.5.5 Photodiodes/Phototransistors

The solution to multicolor sensing at this point seems to lie in the filtered photodiode or phototransistor circuit. The circuit set up is similar to the previous circuits, but an op amp may entirely be ruled out in favor of connecting the phototransistors into a comparator in a binary light detector set up. This method sets a sensitivity threshold for which the comparator will trip from one state (0V) to the next (5V). An LM339 quad comparator is being tested with two of the channels being dedicated to color filtered light detection and the other channels being configured in a way that may prove to provide an absolute color detection scheme. The hypothesis is that if V_{out} from, say the green light detector, goes high before the red light detector then the output will only be green. This is

necessary since both diodes will definitely respond to almost any wavelength, albeit with differing sensitivities, regardless of filtering. However, this difference due to the filtering will be taken advantage of with this technique. If $V_{out,green}$ is connected to $V+$ on one comparator and then $V-$ on a second comparator, and then $V_{out,red}$ is connected vice versa, then this, in theory would allow the absolute decision of color to be made by the comparator.

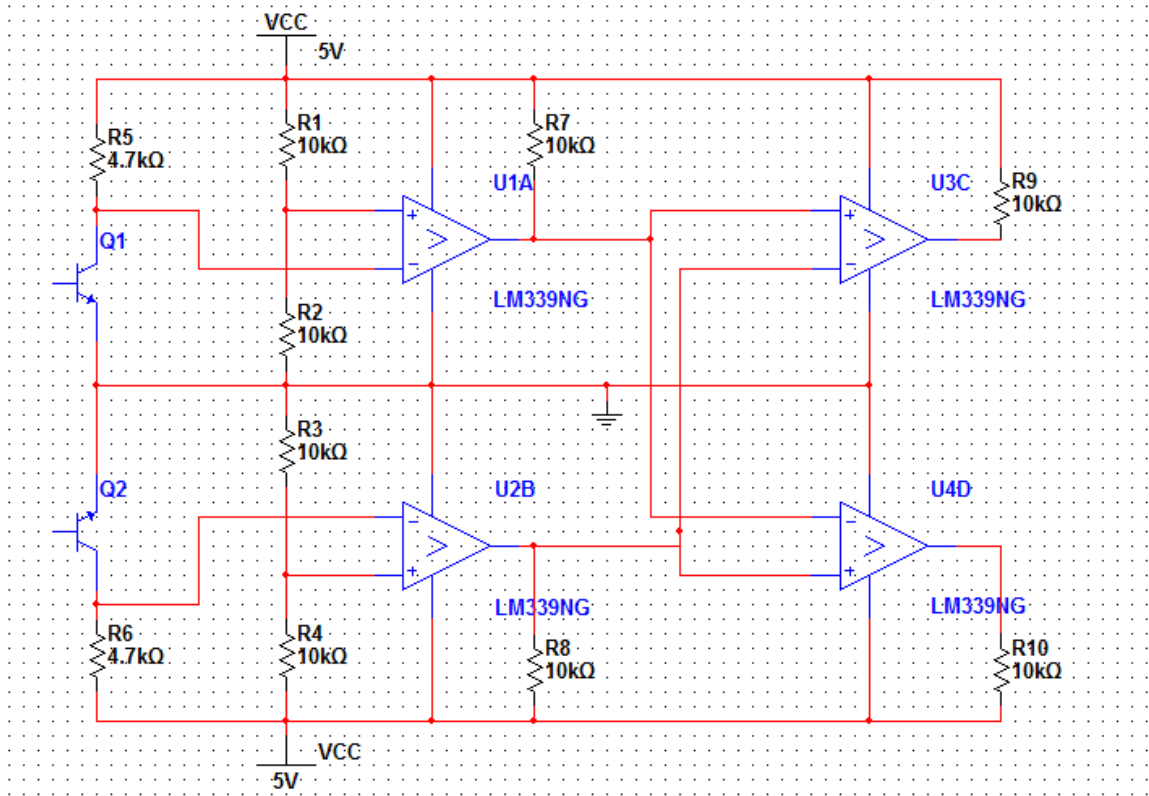

Figure 4.5.5.1

4.6 Software Design

The MSP430G2553 has a total of 16 KB of Flash memory available to store code. The software will be responsible for reading in various inputs, keeping track various statuses, and controlling the peripherals including LEDs, the servo, and the IR “Lazer”.

4.6.1 Headers

The first section of the software will be headers and general setup. It will list the MSP430G2553.h file as an Include. The global variables will be defined as unsigned integers. Global variables can be set and referenced throughout the

entire program as opposed to local variables being limited to a single function. Leaving them as unsigned allows for the use of all 16 bits instead of reserving the MSB for signage. These variables will be used to hold the interrupt flags, allow for the random selection of an item, slowly change the length of delay for flashing lights, keep track of which item (Boost or Lazer) the kart currently has ready, and as counters in For loops and such.

4.6.2 Variables

"flags" – As previously described, when a pin on port 1 with interrupts enabled goes from 0 to 1, the corresponding bit in of the P1IFG register is set to 1 and the software skips to the interrupt service routine. At this point, we want the software to be able to recognize which pin originally triggered the interrupt. However, the interrupt register can be changed by other events. Therefore, the first thing we want to do when an interrupt service routine is called is to save the status of the P1IFG register to the variable "flags". Then the code can systematically examine the bits of "flags" without worrying if interrupts are changing the state of the P1IFG bits.

"itemcounter" – The only function of the main loop other than waiting for interrupts will be to increment a variable called "itemcounter". When the kart drives over an item pickup spot, the kart should have an equal chance of picking up a lazer shot or a speed boost. This randomness keeps the game interesting and pays homage to its "Mario Kart" roots. To achieve this randomness, the main loop will increase "itemcounter" from 0x0000 to 0xFFFF at a rate of 1 per loop. When an interrupt calls the pickup subroutine, it will examine the LSB of "itemcounter". This bit will sometimes be 0 and sometimes be 1, depending on exactly how long the main loop has been running. On average, this structure should allow for a 50/50 split of boosts and lazer shots.

"steptick" - When a kart drives over an item pickup spot, the system should give the appearance of randomly selecting from boost and lazer shot. The items will be represented by a green LED and red LED, respectively. To achieve an interesting visual effect, the pickup of an item should begin a very rapid alternating of the red and green LEDs. This alternating will slow linearly over the course of about 3 seconds until it stops on the selected item's corresponding LED. Because the interval of time between color changes will slow from nearly instantly all the way to half a second between ticks, the variable "steptick" will be used to hold the delay time instead of a fixed number.

"readyitem" - This variable will be used to represent which item the driver has picked up and is ready for activation. If there is no item available, it will be a 0. Speed boost will be represented by a 1 and a lazer shot will be represented by a 2. This variable will be checked and reset by the trigger pull subroutine.

“i” - This is a general purpose counter variable used in For Loops

4.6.3 Setup

Next, setup routines are ran. This section will include things like setting the port direction, enabling on-chip peripherals, enabling interrupts and timers, and initializing variables. Setup will end with three quick flashes of the green LED so the user knows the program is ready.

4.6.4 Interrupts

Most of the function of the Lazer Kart system will be triggered by interrupts. These require a bit of software setup before use. First, the port direction will be set by setting the register PxDIR with 0 for inputs and 1 for outputs. Next, interrupts can be triggered on low to high edge changes or high to low. Our sensors send a high signal upon activation, so port 1 interrupt edge select (P1IES) will be set to 0x0000 for low to high. Then, interrupts will need to be enabled on the pins that need them by setting the corresponding pins of P1IE (Port 1 Interrupt Enable) to 1. Finally, the General Interrupts Enable Register will need to be set (GIE). From here on, state changes from low to high on the enabled ports will cause the interrupt flag for port 1 (P1IFG) to go high and cause the software to skip to the Interrupt Service Routine (ISR).

4.6.5 Timer A

Like the interrupts, the timer used to control the PWM will need to be configured. Many attributes of Timer A are controlled by the control register TA1CCTL. To start with, we will be using output 2, so TA1CCTL2 will need to be set to Output 7 mode. Output 7 mode is the reset/set mode. As explained in the microcontroller section, the timer will reset the output pin upon reaching the CCR2 value and then set it again when reaching the CCR0 value. Next, the appropriate bits of the control register will need to be set as TASSEL_2 and MC_1. This selects the sub-main clock as the source of the timer and sets the count mode to UP. Up mode counts from 0x0000 to 0xFFFF. At 0xFFFF, the timer rolls over back to 0x0000. For PWM, we use 19999 for CCR0. This corresponds to a timer period of .02 seconds. The software can then adjust CCR2 to set the pulse width.

4.6.6 Main loop

The main loop is where the program will wait for an interrupt. The only thing that will happen in the main loop is the incrementing of the itemcounter variable to allow for a semi-random item selection.

4.6.7 Interrupt ISR

When an interrupt is detected, the microcontroller will immediately go to the interrupt service routine (ISR). This ISR will first temporarily disable interrupts so the interrupt is not interrupted. Then, the ISR will use IF statements to determine which sensor caused the interrupt. It will either be an item has been picked up, the boost pad has been driven over, the trigger has been pulled, or the kart has been hit by another kart's laser. Once the event has been determined, the ISR will take the appropriate action. Finally, before returning to the main loop, the ISR will reset the interrupt flag register and re-enable interrupts.

4.6.8 Item Pickup

Once the pickup detector has caused an interrupt, the software will begin the ISR. P1IFG will be loaded into the variable "flags". If "flags" is equal to the bit corresponding to the item pickup, the pickup subroutine will begin. Steptick will be incremented from 0 to 50000 and the red and green LEDs will cycle with a delay of steptick cycles. Then, the LSB of "itemcounter" will be checked and either a 1 or a 2 will be written to the variable "readyitem". Finally, the P1IFG will be reset and the main loop will resume.

4.6.9 Boost Pad

When the boost detector has triggered an interrupt, the Boost subroutine will begin. The green LED will be turned on, the servo will be set using CCR2 to the boost position, and a 5 second delay will begin. Then the servo will be reset to the neutral position and the green LED will be turned off. Finally, the P1IFG will be reset and the main loop will resume.

4.6.10 Hit Detected

When the IR receiver detects a signal from another kart, the kart has been "hit" by the "laser". The ISR will be called. This portion of the ISR will turn on the brake lights and hit indicator lights by setting that pin high, set the throttle servo using CCR2 to the idle position, wait 5 seconds, and then reset the servo position and the lights. Finally, the P1IFG will be reset and the main loop will resume.

4.6.11 Trigger Pulled

Pulling the trigger will trigger the ISR from the trigger pin. This portion of the ISR will check the status of "readyitem". If it is 0, P1IFG will be reset and the main loop will resume. If it is 1, the boost routine will be called as described above. If it is 2, the pin controlling the IR transmitter "fire". The IR transmitter transmits at

56 kHz in a specific pattern. This will be described in detail in the IR section of this report.

4.7 IR Emitters/Receivers

The main lazer system for the LazerKart project will be built using infra-red LEDs and photodiodes.

4.7.1 IR Transmitter

The basic layout is uncomplicated, consisting of a Vishay TSAL6100 high power IR LED operating on a carrier frequency of 56kHz. Using pulse width modulation, a signal will be transmitted that will, when received, inform the receiving unit that it has been hit, and what kart did the shooting. The vital statistics for the LED are shown in figure 4.7.1.1 and taken from the datasheet. Of significant importance is the peak wavelength of 940nm, the angle of half intensity of $\pm 10^\circ$ and the surge forward current of 1.5A at 100 μ s. This allows for a high power signal, that will travel an acceptable distance.

PRODUCT SUMMARY						
COMPONENT	I_e (mW/sr)	ϕ (deg)	λ_p (nm)	t_r (ns)		
TSAL6100	130	± 10	940	800		

ABSOLUTE MAXIMUM RATINGS ($T_{amb} = 25^\circ\text{C}$, unless otherwise specified)				
PARAMETER	TEST CONDITION	SYMBOL	VALUE	UNIT
Reverse voltage		V_R	5	V
Forward current		I_F	100	mA
Peak forward current	$t_p/T = 0.5$, $t_p = 100 \mu\text{s}$	I_{FM}	200	mA
Surge forward current	$t_p = 100 \mu\text{s}$	I_{FSM}	1.5	A
Power dissipation		P_V	160	mW
Junction temperature		T_j	100	$^\circ\text{C}$
Operating temperature range		T_{amb}	- 40 to + 85	$^\circ\text{C}$
Storage temperature range		T_{stg}	- 40 to + 100	$^\circ\text{C}$
Soldering temperature	$t \leq 5 \text{ s}$, 2 mm from case	T_{sd}	260	$^\circ\text{C}$
Thermal resistance junction/ambient	J-STD-051, leads 7 mm soldered on PCB	R_{thJA}	230	K/W

BASIC CHARACTERISTICS ($T_{amb} = 25^\circ\text{C}$, unless otherwise specified)						
PARAMETER	TEST CONDITION	SYMBOL	MIN.	TYP.	MAX.	UNIT
Forward voltage	$I_F = 100 \text{ mA}$, $t_p = 20 \text{ ms}$	V_F		1.35	1.6	V
	$I_F = 1 \text{ A}$, $t_p = 100 \mu\text{s}$	V_F		2.6	3	V
Temperature coefficient of V_F	$I_F = 1 \text{ mA}$	TK_{V_F}		- 1.8		mV/K
Reverse current	$V_R = 5 \text{ V}$	I_R			10	μA
Junction capacitance	$V_R = 0 \text{ V}$, $f = 1 \text{ MHz}$, $E = 0$	C_j		25		pF
Radiant intensity	$I_F = 100 \text{ mA}$, $t_p = 20 \text{ ms}$	I_e	80	130	400	mW/sr
	$I_F = 1 \text{ A}$, $t_p = 100 \mu\text{s}$	I_e	650	1000		mW/sr
Radiant power	$I_F = 100 \text{ mA}$, $t_p = 20 \text{ ms}$	ϕ_e		35		mW
Temperature coefficient of ϕ_e	$I_F = 20 \text{ mA}$	TK_{ϕ_e}		- 0.6		%/K
Angle of half intensity		ϕ		± 10		deg
Peak wavelength	$I_F = 100 \text{ mA}$	λ_p		940		nm
Spectral bandwidth	$I_F = 100 \text{ mA}$	$\Delta\lambda$		50		nm
Temperature coefficient of λ_p	$I_F = 100 \text{ mA}$	TK_{λ_p}		0.2		nm/K
Rise time	$I_F = 100 \text{ mA}$	t_r		800		ns
Fall time	$I_F = 100 \text{ mA}$	t_f		800		ns
Virtual source diameter	Method: 63 % encircled energy	d		3.7		mm

Figure 4.7.1.1

The circuit need to deliver 1A to the LED, which requires a forward voltage of 2.6V. The MSP430 is incapable of delivering this, so the consists of a MOSFET to deliver the PWM signal to the LED. Using our 5VDC rail, that requires a 2.4Ω resistor to deliver the proper current. The circuit is shown in figure 4.7.1.2. A PWM signal will be sent consisting of a 2400μs header and a 5 bit data section indicating the tagging kart. This will allow for up to 32 unique karts to be identified, more than enough for the purposes of LazerKart. This signal can be modified in the future to allow for the optional upgrades. Figure 4.7.1.3 shows an example of a shot from kart number 9.

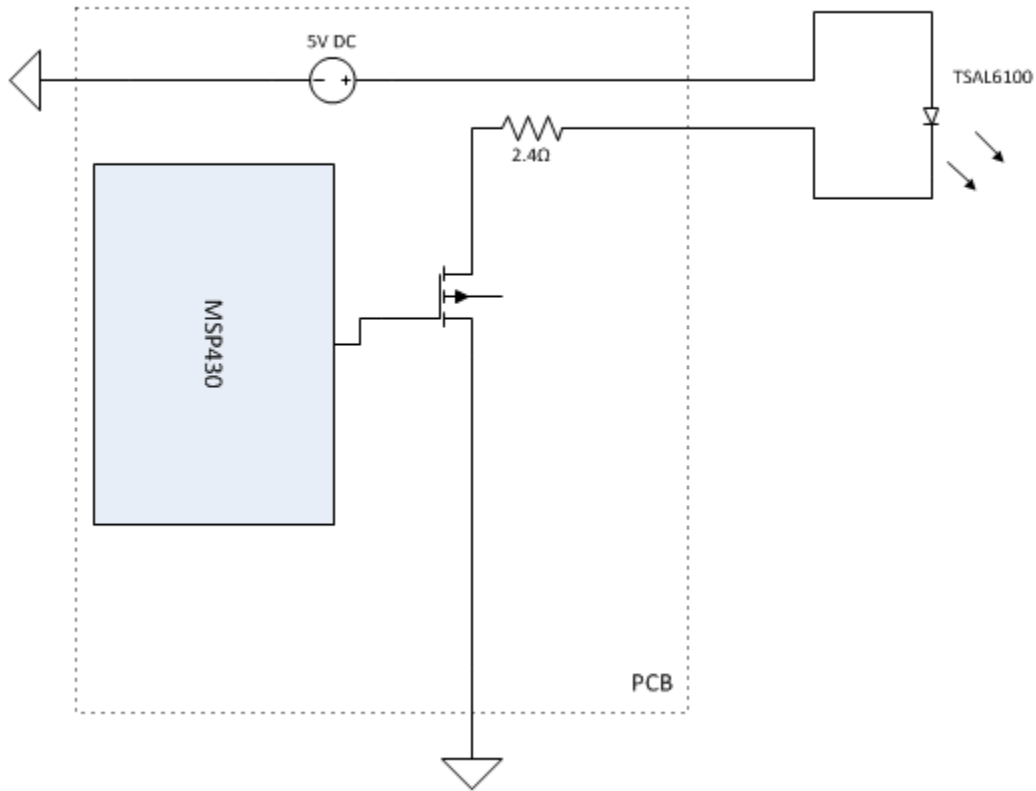

Figure 4.7.1.2

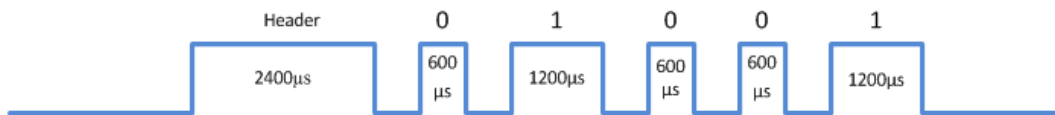

Figure 4.7.1.3

4.7.2 Tagger Housing

The LED needs to be fixed in place, so a housing will be designed out of 1.5" PVC piping. During the testing phase, the piping length will be determined based on the necessities of game play. An attempt will be made to avoid the use of a focusing lens, however the design does not preclude adding one in the future. More specific information regarding the tagger housing will become available upon testing trials. The housing will be fixed to the front chassis bar of the using a circular clamp with rubber grommets to ensure stability. Once the appropriate lens setup is determined, the led will permanently affixed with an epoxy resin

4.7.3 IR Receiver

The IR receiver that was chosen was the Vishay TSOP4856. This is a 56 kHz photo detector and preamplifier that provided an active low signal as an output. It is well matched to out TSAL6100 emitter, with a high spectral sensitivity near or output wavelength of 940nm and shown in figure 4.7.3.1 which is taken from the product datasheet. The Basic characteristics are shown in figure 4.7.3.1, from the product datasheet.

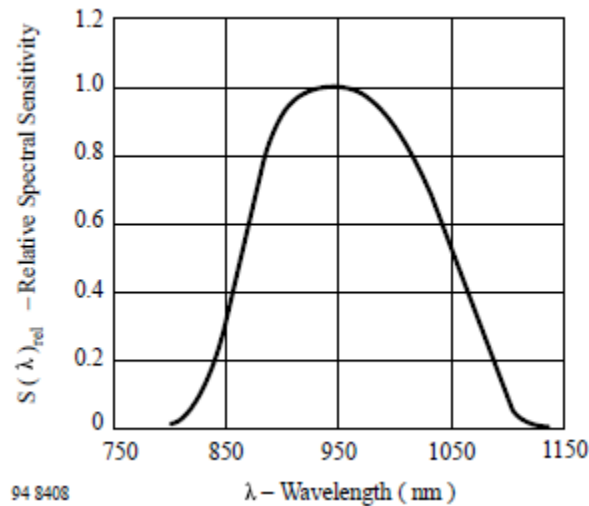

Figure 4.7.3.1

T_{amb} = 25°C

Parameter	Test Conditions	Symbol	Min	Typ	Max	Unit
Supply Current (Pin 3)	V _S = 5 V, E _V = 0	I _{SD}	0.8	1.1	1.5	mA
	V _S = 5 V, E _V = 40 klx, sunlight	I _{SH}		1.4		mA
Supply Voltage (Pin 3)		V _S	4.5		5.5	V
Transmission Distance	E _V = 0, test signal see fig.7, IR diode TSAL6200, I _F = 250 mA	d		35		m
Output Voltage Low (Pin 1)	I _O SL = 0.5 mA, E _e = 0.7 mW/m ²	V _O SL			250	mV
Irradiance (30 – 40 kHz)	Pulse width tolerance: t _{pi} - 5/f _o < t _{po} < t _{pi} + 6/f _o , test signal see fig.7	E _e min		0.2	0.4	mW/m ²
Irradiance (56 kHz)	Pulse width tolerance: t _{pi} - 5/f _o < t _{po} < t _{pi} + 6/f _o , test signal see fig.7	E _e min		0.3	0.6	mW/m ²
Irradiance	t _{pi} - 5/f _o < t _{po} < t _{pi} + 6/f _o	E _e max	30			W/m ²
Directivity	Angle of half transmission distance	φ _{1/2}		±45		deg

Figure 4.7.3.2

The circuit necessary for the receiver consists of the MSP430 mounted on the PCB, with connections for the output and brake light to the receiver dome. The receiver dome will consist of the TSOP4856, and a 100Ω resistor and 4.7μF capacitor to power supply disturbances as recommended in the datasheet. Because the receiver will be mounted on the rear of the kart, it will also serve as the brake light and hit indicator. The circuit also contains 8 ultra bright red LEDs made by China Young Sun LED Technology Co. LTD. To get the 20mA forward current, requires 2.4 VDC across the LEDs and a total of 160mA of current through the resistor, this is accomplished with a 15Ω resistor. The circuit is shown in figure 4.7.3.3.

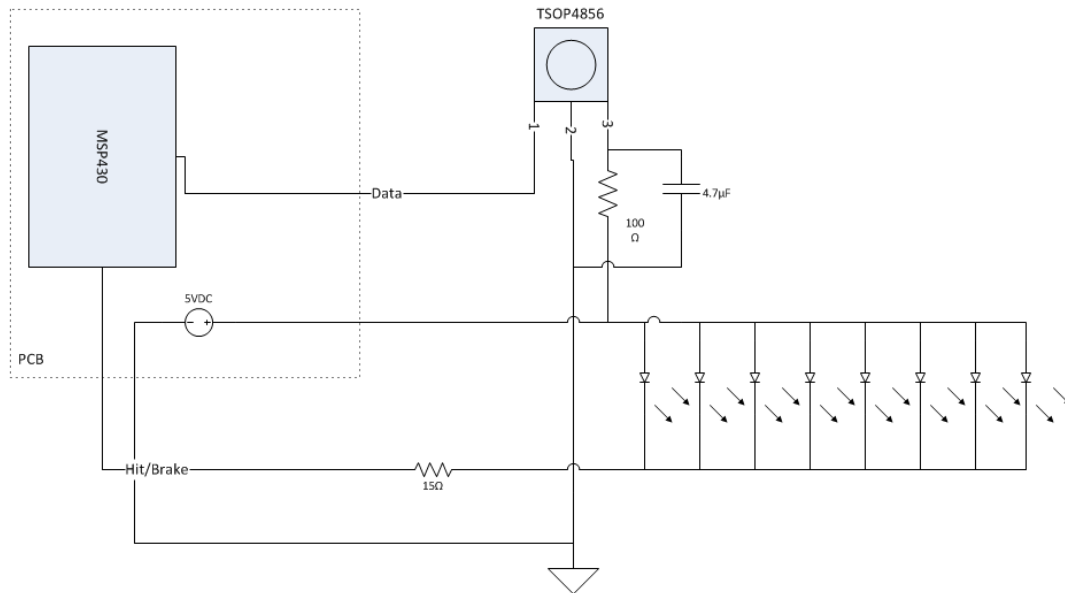

Figure 4.7.3.3

4.7.4 Receiver / Brake Light Housing

The receiver break light housing will consist of 2 domes, a black IR dome nested inside of a transparent dome. This will allow for additional protection against interference from outside light sources, as well as protect the system. The clear dome will house the 8 ultra bright LEDs as well as the IR dome. These domes will be sealed from the elements using a clear epoxy resin. The ultra bright LEDs will be arranged two on each side of the IR dome, top, bottom left and right, for maximum vision.

4.8 Throttle Linkage and Servo

One of the main functions of the Lazer Kart system is its ability to regulate the kart's engine speed. This is what allows for speed boosts due to item pickups or boost pad crossing. It also allows for the engine to be cut to idle when the kart has been hit by another driver's "lazer". To achieve these responses, the Lazer Kart system includes a servo motor connected to a throttle regulator on the engine.

The karts that our system will be used on are equipped with the Honda GX270 motor. This engine is a small gas powered, 4 stroke motor with one 77x58 mm cylinder. It has a displacement of 270 cubic centimeters and puts out a maximum of 8.5 horsepower. For engine speed regulation, it uses a centrifugal mass type governor. This governor functions by using a spinning mass inside the engine to move a control arm that is mounted on top of the engine. This control arm is connected to the engine's throttle. It is this control arm that the servo will attach to. In this way, the servo will override the governor and force the engine to either full power or to idle.

4.8.1 The Engine Governor

The engine governor control arm is mounted on top of the engine. It is double sided. The right side (as viewed from the rear of the kart, also the driver's right) is 5.5 inches long and ends in a small connecting hole attached to a push rod that connects to the engine's throttle on the carburetor. The left side is 1.25 inches long. It is attached to a return spring that acts to hold the governor in a neutral position. The arm is mounted on top of a pivot point with a friction adjustment screw on top. This is shown in Picture 4.8.1 below.



Picture 4.8.1 Top view of the engine governor

4.8.2 Servo Mounting

As shown below, beginning 2.5 inches in front of the governor control arm pivot point is a 1 inch bracket mount. This mounting post supports a large red heat shield that protects the top of the engine and covers the governor arm. This red heat shield conveniently has a hole pre-drilled on either side of the mounting hole. This is where we will attach our servo bracket. This is shown in the following two pictures (Pictures 4.8.2.1 and 4.8.2.2)



Picture 4.8.2.1
Heat Shield Bracket



Picture 4.8.2.2
Heat Shield

4.8.3 Servo Bracket

The Servo Mounting Bracket will drop 2 inches down and 1 inch forward from the top of the red heat shield. It will be mounted to the holes on either side of the heat shield mounting hole. The mounting bracket will have 3/8 inch holes on the top tabs to mount to these preexisting holes. The base of the mounting bracket will be 2.5 inches wide with a centered cut out that is 0.91 inches long and 0.48 inches wide for the servo to sit in. There will be 0.2 inch holes on either end of the cut out for servo mounting bolts.

4.8.4 Servo Location

Once mounted in the bracket described above, the servo will be positioned 5 inches as measured in a straight line from the hole currently occupied by the centering spring on the left side of the governor arm. There will be a thin metal cable attached to either end of the servo horn. The other end of these cables will be attached to the governor control arm. On the left side, the cable from the servo will be 5 inches long and attached to the existing mounting hole. On the

right side, the cable will be 7 inches long and attached to the existing hole at the end of the governor arm.

4.8.5 Servo and Arm Movement

Attached to the top of the servo will be a 1.25 inch horn, with 0.625 inches extending from the center on each side. The commands for idle and full throttle will rotate the servo ± 45 degrees from center. At this rotation, the end of the horn where the cable is attached, will travel 0.44 inches forward ($\sin(45) \cdot 0.625$) and $.18$ inches sideways ($0.625 - (\cos(45) \cdot 0.625)$) for a total movement of $.475$ inches. This nearly half inch movement is more than enough to open the throttle to full or close it to idle.

4.8.6 The Servo

The servo that will move our engine must meet several conditions. First, there are two types of servos. The first and older type is the analog control type servo. This type of servo uses standard pulse width modulation to command a desired rotation angle. Any deviation from this angle will result in torque being applied to reach the desired angle. The standard period for this pulse width modulation signal is $20 \mu\text{s}$. Therefore, that is how long the servo goes between updates. The issue with this is that the pulse width is usually between 1 and 2 ms. A short pulse every 20 ms allows for a bit of wiggle room in the servo position. Also, it does not allow for much torque to be applied for small movements.

The other option is a digital servo. A digital servo accepts the same pulse width modulation signal, but it contains a small microcontroller that processes the signal and sends upwards of 300 pulses per second to the servo motor (depending on the model). This will allow for higher torque and faster reactions, but consumes a lot more power. While a standard analog servo may use 0.1 to 0.2 amps while turning, a digital servo can use up to 2 amps. Such a high draw would be undesirable for our Lazer Kart system. Also, small time delays and very slightly off target rotations are not an issue for the Lazer Kart system. Therefore, we have elected to go with an analog servo.

In addition to control types, servos are also sold with different gearing material options. The cheapest hobby servos use nylon or plastic gears for the power train. These are cheap and light weight, but are not very durable. As this project will be used in a commercial application, we require more durability. The next step up is a material by Hi-Tech known as Karbonite. Karbonite is a very durable material marketed as 3 to 4 times stronger than nylon gears and very wear resistant. It is also a brittle material that is prone to shattering at high loads because it has no "give" like nylon. Again, we require higher durability. Finally we come to metal gearing. For a bit more money and weight, servo companies offer servos with all metal gear trains that provide for superb reliability and strength. Metal gears are not always the best product, because they can wear down a bit over time. This can allow a little variance in the rotation angles, but 1

or 2 degrees isn't an issue for our application. Therefore, we have selected a metal gear train servo.

Specifically, we have chosen the Corona 939MG Metal Gear Servo.

Corona 939MG Metal Gear Servo Specifications

Power Voltage:	4.8 – 6 Volts
Max Current Draw at 5 V:	210 mA
Stall Torque:	2.5 kg.cm
Width:	12 mm
Length:	23 mm
Price:	\$4.37 from hobbyking.com

4.8.7 Controlling the Servo

As described above, servos use pulse width modulation for their control. In this application, the pulse width signal will be generated by the MSP430. For this, the MSP430 timer will have to be programmed with a period of 20 ms. Additionally, the servo will require signals that command a neutral position, a clockwise rotation of 45 degrees and a counterclockwise rotation of 45 degrees.

The MSP430 timer operates in terms of clock cycles, so multiplying the sub main clock frequency of 1000000 cycles per second by .02 seconds gives 20,000 clock cycles for the period. Subtracting 1 because the counter will roll over at this point, we load 19,999 into CCR0. See the microprocessor section for more information on the Timer A control registers.

Now, to find the values for CCR2, the range of the servo PWM input signal is divided by the range for that signal. In this case, we subtract 600 μ s from 2400 μ s and divide by 180 degrees to get a pulse width of 0.00001 seconds per degree with a neutral point of 1.5ms. For +- 45 degrees, the required commands are thus a PWM signal of 1.05 ms duration and 1.95 ms duration, respectively. Multiplying by the clock rate gives a neutral position commanded by 1500 clock cycles and +- 45 degree positions given by 1050 cycles and 1950 cycles respectively. These are the values to be loaded into CCR2 as described in the PWM subsection of the microcontroller section.

4.9 Optional Modules

4.9.1 8x8 LED Matrix Display

The standard LazerKart implementation will utilize two indicator LEDs located on the steering column of the go-kart to notify the driver that they have acquired an item from the track. A red LED will indicate that the driver has acquired a lazer activating item and a green LED will indicate that the driver has acquired a speed boost from the track. This method of indication is simple and effective, but if time permits, an alternative method would be to utilize an 8x8 RGB LED display to indicate various items and possibly other activities. The display would really benefit from the additional inclusion of a ZigBee network and could display information that might be transmitted to and from another kart, such as a target lock-on or whether a kart was hit by a certain driver. The LED matrix could greatly enhance the LazerKart experience visually.

The 8x8 LED matrix is a single component package that contains a total of 192 LEDs (8x8xRGB). A particular design that could make efficient use of a MCU with limited IO pins will require the use of shift registers. The 74HC595 8-bit shift register is appropriate for consideration in this circuit. This particular shift register can communicate via SPI with a microcontroller, requiring no more than 4 pins. Three 74HC595s would be used to control the RGB rows and one would control the columns. The microcontroller would apply pulse width modulation (PWM) to each LED in order to create a multitude of colors. Perhaps 4-bit PWM would suffice, as 16 colors would be enough to attract the driver and wouldn't overtax the microcontroller.

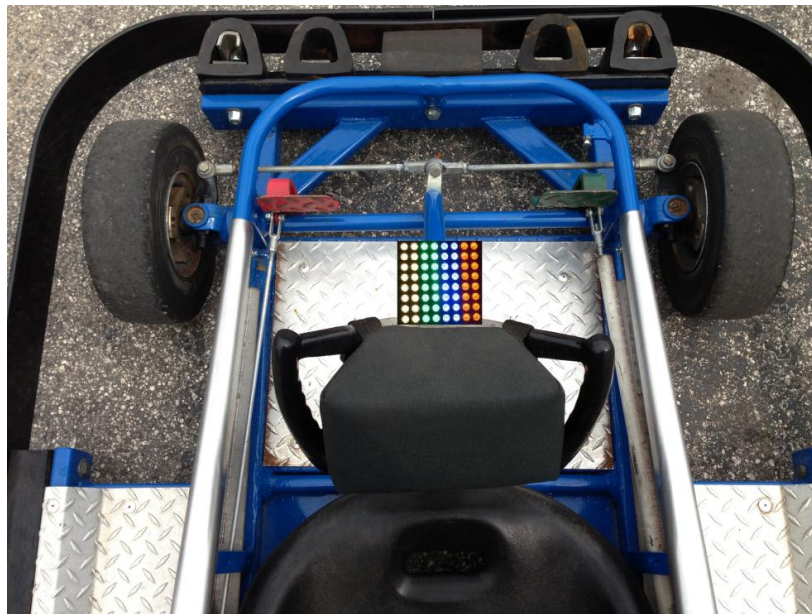

Fig. 4.11.1.1: Mock-up of 8x8 LED matrix above steering wheel

According to a similar project on instructables.com, the designer was able to implement this configuration using an Arduino MCU and still had 50% of the MCU's resources available to utilize perhaps I²C or serial communication for other peripheral features, thus there it is possible to transmit and receive data to and from the main microcontroller. The LazerKart system will try to implement this type of design using a TI MSP430 MCU if possible. Another similar design was able to use a more advanced Parallax Propeller MCU with no shift registers on a compact PCB with a startup power consumption of 0.6W and a runtime power consumption of 0.275W, so it is feasible to add such a unit onto the LazerKart system in terms of power availability.

The matrix display would be programmed utilizing existing graphics libraries for an Arduino, Parallax, or Atmel microcontroller to cut on development time. The development community is fairly strong in the LED matrix hardware and software design. The total display circuit, including microcontroller, LED matrix, shift registers, passive components, etc., could be incorporated onto its own relatively small PCB and mounted in a weatherproof enclosure within a shock absorbent, cushioned pad bracketed to the steering column.

Possibilities for graphical notification include displaying flashing or animated sprites and/or scrolling text that indicate:

- IR Weapon Activated
- Speed Boost Acquired
- Boost Zone
- Target Lock-On
- Invincibility
- Slow All Other Karts (If ZigBee is used)
- Successful IR Lazer hit/ Hit by IR Lazer
- Scoring/Placement (optional)

A problem could be encountered with daylight visibility, so it may prove to be a financial setback to develop a working prototype for this module just to find out that it isn't very visible during daytime. The RGB matrices themselves cost anywhere between \$8.00 and \$25.00, depending on the vendor, each shift register costs less than \$1.00 and resistors, capacitors, and header pins are relatively inexpensive. A separate PCB would need to be designed thus increasing the price yet again, so the total cost of testing and designing this module could be anywhere from \$35-\$50.00 and that is assuming the MSP430 couldn't handle the requirements and excluding any costs for other MCU development boards. Thus, time and budget constraints seem to be a downside to this otherwise unique enhancement to LazerKart.

4.9.2 Accessory LED lighting

One of the optional modules is to add LED lighting to the go-karts. The idea is that when one of the karts sensors is activated there will be a colorful light display around the driver. The lights will allow the surrounding drivers to see that another driver has acquired a weapon, fired a weapon or have been hit by an opponent. The LED light will add an exciting, aesthetically pleasing addition to the game, attracting customers yet still playing a role in gameplay dynamics.

One option is to build a prototype LED strip from scratch but this would require a lot of unnecessary time and effort spent, considering there are a number of programmable RGB LED strips available on the market and the that LEDs are an addition to the game, not part of the core functionality. A popular strip on the market is the addressable RGB 30-LED Strip made by Pololu Robotics and Electronics® seen in Figure 4.11.2.1.



Figure 4.11.2.1 Addressable 30-RGB LED strip

According to the Pololu website, this particular strip has a driver IC for each LED, allowing the color of the LEDs to be controlled independently. The karts AC coil has a maximum current output of about 3A while the LEDs use about 1.8A, so the number of LEDs installed will have to be limited to only a few. An alternative means of powering the LEDs is through the use of batteries, to avoid overloading the AC coil and for demonstration purposes. The use of batteries will also allow for more strips to be used (Addressable RGB).

The strip has a 5V operating voltage which is a voltage that happens to be available on one of the regulators powering the weapons acquisition circuit so this system will be easy to incorporate into the power system. Some additional features of the LED strip are listed below (Addressable RGB).

Features include:

- 24-bit color (8-bit PWM channel); 16.8 million colors per pixel
- One wire communication
- Waterproof
- 3M adhesive backing
- Data input/output connector

The protocol for the LED strip involves using a high-speed one-wire connection using a series of high pulses where $0.7\mu\text{s}$ in duration, represents a zero, while long pulses $1.3\mu\text{s}$ in duration are representative of a one. The time the signal needs to stay low after sending high pulses, is $2.5\text{--}9.0\mu\text{s}$. There is a large range of acceptable pulse widths that will still register as a one or zero, reducing the amount of precision needed to display the colors. After sending the serial bits the line is then held low for $24\mu\text{s}$ to send a reset command, which updates the colors displayed. The timing for the strip is shown in Figure 4.11.2.2

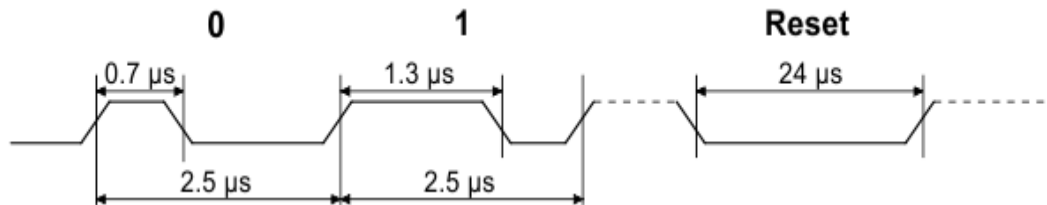

Figure 4.11.2.2 pulse timing diagram for LED strip

Each color is encoded as three red, blue, green LED brightness level using 8 bits each. The MSB of the 24-bit number is sent first. The first 24-bit number, before a rest period is sent, is for the first LED, each 24-bit number sent thereafter is for the next LEDs and so on. If all 30 LEDs are to be updated the numbers should be sent consecutively without the $24\mu\text{s}$ reset time, sending a total of 720-bits. Additionally, constant updates are not necessary because the LED strip can hold its state indefinitely as long as power remains connected. A bit placement is shown in Figure 4.11.2.3 (Addressable RGB).



Figure 4.11.2.3 RGB 24-bit placement.

The desired displays will include three different light sequences, one for each of the three laser kart's primary functions; (1) the weapons acquisition; (2) using the weapon acquired; (3) being hit by a weapon.

The light effect for when a rider picks up a weapon will look as though the kart is charging up with light “energy”. This effect will go from dim to fully bright in a 5 second period and remain bright until the user chooses to fire the weapon. The final color of the light can vary from kart to kart so that there is a clear distinction between riders, giving the game a more colorful appearance.

The display for when the rider fires their weapon will appear as though the shot is running along the sides of the kart. The LEDs closest to the back will light first then each consecutive light will turn on until the light nearest the front is lit before the sequence starts over. Again, this display will last a few second.

The third light effect for when an opponent is hit will be a sequence of red flashes using all the LEDs, appearing as though the kart has malfunctioned.

The next important feature to consider is choosing microcontroller. One option is to use the MSP 430 since it is already available on the kart’s PCB. The MSP 430 has plenty of processing power to perform the light display and is inexpensive, however, the one currently on the PCB only has one pin available so using multiple strings of LEDs on the kart may be difficult to implement. Another option is to use I2C and purchase another MSP 430 used solely for the LED display. A third and more costly solution to running the LED display is to use an Arduino MCU. The lines from the weapons acquisition and IR transmitter and receiver can be used as inputs on the Arduino to create the light display eliminating the need for I2C. There are many similar projects using the Arduino and available libraries for programmable LED displays. Example code can be found at Pololu.com, including step-by-step instructions describing how to use install and the libraries. The time and effort spent will be on getting the lights to display in the three patterns previously described.

The example code in the libraries include a color gradient display that allows you to see the various colors in sequence along with a color tester sample code which allows you to choose any to display any color. The samples will be a useful tool when trying to learn the programming processes. As mentioned before the LED strip takes around 2ms to update all the lights in a single strip. The library disables interrupts using in order to accurately update the LED strip, however, this function causes issues with other programs using interrupts. The library contains an ‘interruptFriendly’ command that allows the library to coexist with other programs using interrupts but the LED strip will interpret any interrupt longer than 8µs as a reset signal, causing unwanted flashes in the lights so any interrupts must be for a short duration making it even more necessary to use a separate MCU in addition to the MSP430 (Addressable RGB).

As previously stated, the various colors are encoded using 24-bits. The available libraries define a type named ‘rgb_color’, used to represent colors. The colors are defined as three numbers between 0 and 255 for the red, blue and green respectively, where 255 is the brightest value (Addressable RGB).

The library uses a 'pin' template parameter that is used to define the pin that the LED strip's data input line is connected to on the MCU. There are many user friendly commands and definitions such as the ones listed above that will allow for relatively hassle free programming should the Arduino be used.

It should be noted that the accessory LED display goes hand-in-hand with another optional module, the 8x8 LED graphics display. If the display is built, both the accessory LEDs and the 8x8 graphics will easily fit on the same Arduino board.

Addressable LED strips cost anywhere from \$10.00 to \$40.00 depending on length and the manufacturer. The total cost of adding the accessory LEDs is around \$50.00 if the MSP 430 cannot handle the additional but may be as little as \$20.00 if the only additional hardware needed is the LED strips themselves.

4.9.3 ZigBee Mesh Network

One of the core optional additions will be the wireless communication module to be added upon the successful implementation of the basic game system. For this, a ZigBee mesh network has been selected.

After consideration, the module chosen was the Telegesis ETRX2-PA. This module allows for configuration as a ZigBee End Device (ZED) Router (R) or Communicator (C). This device comes with an integrated antenna, and with an overall dimension of 37.5 x 20.5 x 3.2 mm will be able to be integrated onto the existing PCB with I²C. Using the 2007 ZigBee Alliance protocol, gives the added benefit of self-healing mesh networking and improved point to multipoint message transmission through source-routing. This will aid in the multi-kart control aspect of the project. An operating supply voltage range of 2.7 -3.5 VDC fits well with the power available to the project. Figure 4.9.3.1 shows the hardware diagram from the Telegesis datasheet.

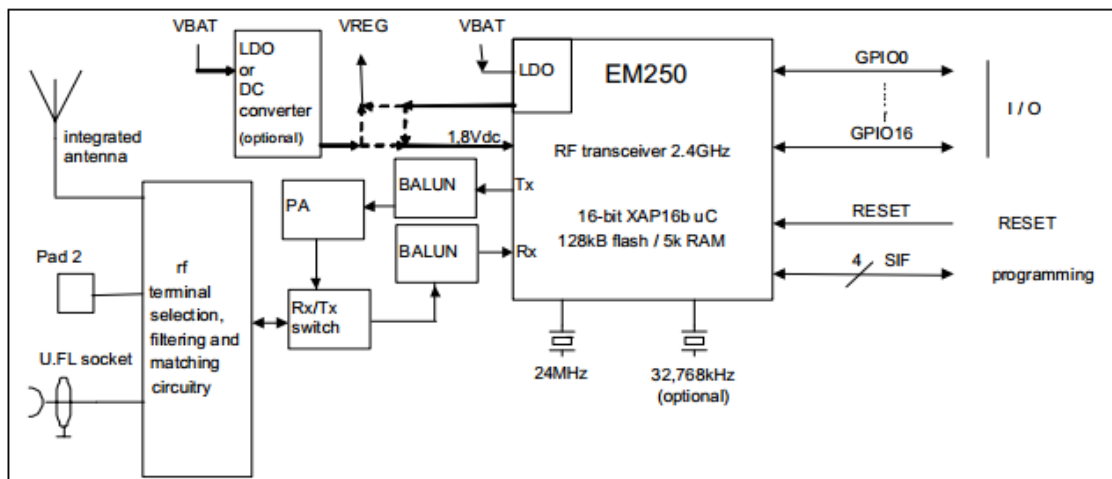

Fig 4.9.3.1

4.9.4 Audio Components

4.9.4.1 Sound Effects Concept

One feature that will allow for project scalability is the use of audio components to add sound effects to a game of Lazer Karts. Like the LED light effects, this module will play a short .wav file when the microcontroller senses a weapon/boost acquisition, the driver fires the weapon or if the kart is hit by an opponent. Each function will address a different .wav file. Like the LED strips this module will only be built considering there is enough time and available budget to do so.

When a driver picks up a weapon/boost the desired sound will be a “power up” effect that gets louder to give the driver the feeling they are speeding up or that the lasers are charging and ready to be used. Another desired sound will be the “power down” effect that goes from louder to quieter when the Kart is hit by an opponent. The third sound effect “firing” will be played when the driver uses the lazer. These sounds will play simultaneously with the LEDs responding to the same in game functions.

A second option is to add vocal sound effect, either by themselves or at the same time as the corresponding sound effects described above depending on if the shield can play multiple .wav files at once or not. The vocals could include “charging lazer!” or “weapon acquired!” when a lazer is picked up. Alternatively, the vocal effect could include “firing lasers!” or “speed boost!” when either a weapon or boost is used respectively. When a kart is hit by an opponent the vocal sound effects could say “malfunction!” or “system failure!”.

4.9.4.2 Software/Hardware

Since adding sound effects to a project from scratch is a difficult task the use of available wave shields will be considered. This will cut down on development time but still give the designer the opportunity to learn new audio software and hardware integration methods. One source that has detailed information on how to build, use and install this type of project is Adafruit Industries (Adafruit). The website offers tutorials, open source libraries, required equipment, file conversion steps, and steps-by-step instructions on how to assemble the parts board. Listed below are some of the key features of the audio shield.

- The shield comes with an Arduino library for easy use
- Can play any uncompressed 22KHz, 16bit, mono Wave (.wav) files of any size. While it isn't CD quality, it is certainly good enough to play music, have spoken word, or audio effects.
- Output is mono, into L and R channels
- Standard 3.5mm headphone jack and a connection for a speaker that is switched on when the headphones are unplugged.
- Files are read off of a FAT16/FAT32-formatted SD/MMC card
- Included library and examples makes playing audio easy

- The library bulky, requiring 10K of flash and more than 1/2 K of RAM for buffering audio. It works fine using an yATmega328-based Arduino

There will have to be considerations regarding the amount of power the speakers will require. The recommended size of the speakers for this module is 3 inch diameter, 8 ohm, 1 watt speakers. Since the sound effect are mono then the system will work well with only one speaker but since the sound effect will be played at the same time as the LED lights, microcontroller processing and use of the IR Tx/Rx module there will be more than 3W being drawn from the AC coil. To include the sound effects it will almost certainly require the use of batteries. These issues will be addressed when testing the audio components.

There is an issue with the amplitude of the sound that this system can output as it will be competing with the noise produced by the engine possibly making it necessary to increase the size of the speakers. An alternative solution could be to use a pair of headphones that can be mounted on the kart for use while driving cancelling the majority of the sound produced by the engine, however, this will add additional cost to the project. The use of headphones will only be considered if the budget permits and if the engine is in fact too loud for the speakers to be heard. Again, the use of audio components to make sound effects is only an addition and is not part of the core Lazer Kart system.

This module is relatively low cost if there is no need for an additional microcontroller. The module is only \$22.00 making it an affordable add-on to the project.

4.9.5 No Bumping Sensor and Warning

4.9.5.1 Motivation

While researching this project, our group made several visits to Fun Spot. We spoke with the owner, the mechanics, and the track operators. We discovered that one of their biggest concerns is reckless driving, specifically drivers bumping into other karts. These karts travel at speeds up to 20 miles per hour. Reckless ramming into other karts is not only a safety issue, it is also a maintenance issue. Repeated impacts are rough on the karts, the steering linkages, and the power train. These must all be adjusted by maintenance on a regular basis and constantly banging into other karts increases this work. There are “No Bumping” warnings posted all around the track as well as on the karts, but we are told by Fun Spot staff that they are mostly ignored. Therefore, a possible addition to the Lazer Kart system is a Bumping sensor integrated with the microcontroller.

Our No Bumping warning system would use an accelerometer to detect if a driver has rammed into another kart. When this is detected, the microcontroller will illuminate a sign reading “No Bumping!” and then cut the kart's engine's throttle as if it had been hit by another driver's lazer.

4.9.5.2 Accelerometer Requirements

The only additional hardware required for the No Bumping sensor will be an accelerometer. This accelerometer need only detect acceleration in a single axis as it will only be looking for rapid speed changes in the karts forward speed. It will also require a small g sensing range. Personal testing has shown that most bumping induces a negative acceleration of no more than 2-3 g's. The exact g value will be refined with additional testing once the unit is installed. An accelerometer with a range of +/- 5 g's should be sufficient without losing too much resolution. The biggest choice in accelerometers is analog or digital. Analog accelerometers output a voltage proportional to the load on them. Digital accelerometers output serial data that can be read and decoded by a microcontroller. While digital units are more accurate and the data can be read directly by the microcontroller, they require polling by the microcontroller. In our application, we hope to not ever use them so frequent polling would be wasteful. A better option is to use the analog output of an analog accelerometer to trigger an interrupt in the microcontroller code. Therefore, our system will use an analog accelerometer that outputs a voltage proportional to its loading.

4.9.5.3 Selection

After looking at several options, the Analog Devices ADXL325 accelerometer was chosen for this application. It operates on 3.3 V Vcc, has a range of +/- 5g's, a low power draw of 350 μ A, and an analog output. It is a 3 axis accelerometer, but is very inexpensive at only \$6.25 from digikey.com. There are several single axis accelerometers available on the market, but they are nearly all designed for higher loads in the 25 – 200 g range. They are also quite expensive. It has become industry standard to include three accelerometers in a single inexpensive package. In fact, the sensor uses one structure to measure all three accelerations. So, in this case, it is more cost efficient for this project to use a three axis accelerometer and only use one of the three outputs.

4.9.5.4 Output Voltage

The datasheet of the ADXL 325 states that at zero g's, the output of the accelerometer will be one half the source voltage, which in this case will be 3.3V. Therefore, the zero g voltage will be 1.65 Volts. The voltage dV/dg is 190 mV when Vcc = 3.3 volts. That means that an "x" g deceleration will be indicated by $1.65 - (.19 \times x)$ Volts. Again, the exact g force experienced during a collision will need to be refined by testing.

4.9.5.5 Interaction with Microcontroller

As just described, the accelerometer will output an analog voltage depending on the acceleration experienced. The microcontroller could read this voltage through an analog to digital converter port, but that would require a lot of polling of the port, and even then, a quick bump might be missed because the

microcontroller was doing something else. A better solution is to once again use an interrupt. As an example, we will assume a -2 g deceleration here. This value may change, but it is just a matter of changing the resistor values to compensate. A voltage corresponding to a -2 g bump should trigger an interrupt on one of the microcontroller's input pins. To do that, however, a comparator is required. A comparator will output either a high level or low level depending on if the V+ or V- is higher. In this application, Vcc will be 3.3 volts. As described above, a -2g bump will cause a voltage of 1.27 volts. Means that when the input voltage on the following comparator circuit is less than 38% ($1.27/3.3 = 38\%$) of Vcc, a -2g bump has occurred and the output going to the input pin will go high triggering an interrupt.

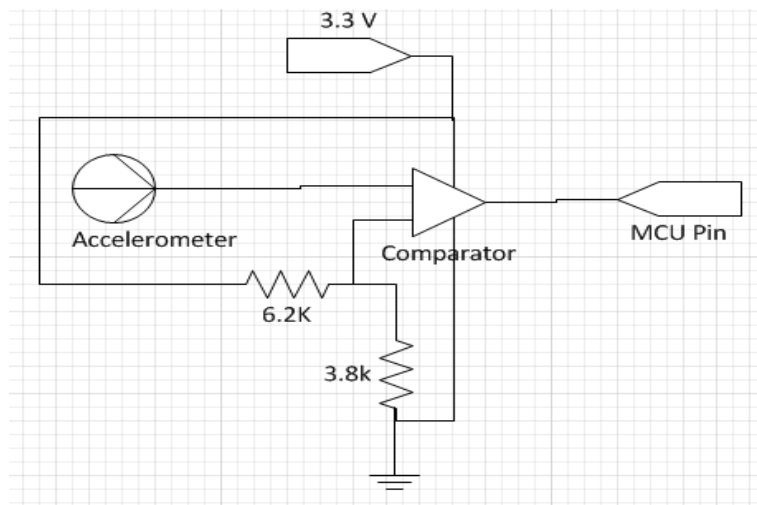

Figure 4.9.5.5.1 No Bumping Schematic

Once the interrupt is triggered by output of the comparator going high, the interrupt service routine will be called that will set the servo to the "idle" position for 5 seconds and light a small NO BUMPING sign in front of the driver.

The intent is for this system to reduce the amount of reckless driving, increase safety, and reduce wear and tear on the karts.

4.9.6 Hand Held IR Transceiver

The Lazer Kart system is designed to be used by multiple karts, all equipped with identical systems that interact with each other as they race around the track. As such, the system will be fully tested using multiple karts before it is deployed. However, that will not be the only testing done. To test multiple karts interacting, multiple karts would first have to be built. If a flaw is discovered after multiple karts have been built, it is more expensive and time consuming to go back and fix all the karts. The flaw should have been detected earlier. As such, we will be

first building just one kart and then testing it with simulated signals from other karts. That is, instead of building a second or third kart for testing purposes, we will build and use a small, hand-held IR testing tool. It will consist of an IR receiver, an LED to indicate reception status, an IR transmitter, and a MSP430 all mounted on a development board.

The primary means of interaction between karts will be the infrared transmitter and receivers. As such, our hand-held testing unit will combine these two functions into an easy to use unit that can be used to test the IR sending and receiving capabilities of the karts.

4.9.6.1 IR Receiver

Just like on the kart itself, the IR testing transceiver will use the Vishay TSOP IR receiver configured for 56 kHz reception. As described in depth in the IR Transmitter and Receiver's section of this report, the IR receiver is tuned to detect a 56 kHz signal and pull the output low while a 56 kHz signal is being received. All of the complicated signal processing is done inside the receiver for a nice, clean Vout of either Vcc or ground depending on if a 56 kHz signal is being received. While that will be used on the actual kart system to trigger an interrupt, on the testing platform we will only use it to turn off an LED to indicate the reception of the signal.

4.9.6.2 IR Transmitter

The lazer kart system will use the Vishay TSAL6100 high power IR emitter as the transmitter or "lazer". As discussed in the IR Transmitter and Receiver's section of this report, the TSAL6100 will need to operate on a carrier frequency of 56 kHz. To achieve this, the IR transmitter will be controlled by another MSP430 in the testing unit. The MSP430 will be connected to a push button that will act as the trigger. Whenever the button is pressed, the MSP430 will call a function that will output a 2 second 56 kHz signal. The testing system will need to send pulses with period 1/56000 seconds for the duration of 600 microseconds. This works out to:

Period of Carrier Frequency: $1/56000 = 1.78e-5$ seconds

This carrier frequency is a square wave with amplitude varying between fully off and fully on. As such, the time of being on will be one half the period:

Length of "on" time: $.78 e-5 / 2 = 8.93e-6$ seconds

The MSP430 in the testing unit will be running at 16 MHz. To find the number of clock cycles the “on” command should be given:

Cycles for each pulse: $16e6 * 8.93e-6 = 142.85$ cycles

Obviously, we can't do anything for 0.85 clock cycles, so this will be rounded to 143 cycles. This will actually give an on time of

$.0006 / 1.78e-5 = 8.9375e-6$

And a period of

$8.9375e-6 * 2 = 1.7875 e-5$ seconds

For a frequency of:

$1/1.7875 e-5 = 55.944$ kHz

As described in the previous subsection, this will be close enough to the nominal 56 kHz rate for successful reception by the receiver. It is worth mentioning here that the rise and full times of this LED are around 800 ns. This is not long enough to material affect the transmit rate. These low times are one of the reasons we selected this IR LED.

Now that we know we will be turning the IR LED on for 143 cycles, then off for 143 cycles to generate a carrier frequency of 56 kHz. This will need to be repeated for as long as we want to be transmitting a “lazer” shot. We have chosen a 2 second time period for this although this may be adjusted during play testing.

4.9.6.3 Transmitter Power

The Vishay 6100 IR emitter is rated for a surge current of up to 200 mA for a duration less than 0.0001 seconds (100 us) at 50% duty cycle. Our pulses will be much shorter (about 0.000009 (9 us) seconds) in length, so there should be no issue with running .2 A through this LED. This is, however, more current than the MSP430 can source. The MSP430's output pins are limited to around 40 mA (depending on voltage). Therefore, a N-Channel MOSFET controlled by the microcontroller will be used to power the transmitter.

4.9.6.4 Receiver Circuit

As shown below in Figure 4.9.6.1, the IR receiver is powered by 3.3 Volts. The output voltage will be 3.3 volts until something is received. This will be indicated by the LED. The current on the output pin must be limited to 5 mA. The LED has a 2 volt forward voltage, so the resistor must be

$R = V/I = (3.3 - 2) / 0.005 = 260$ ohms. This will protect both the LED and the IR receiver.

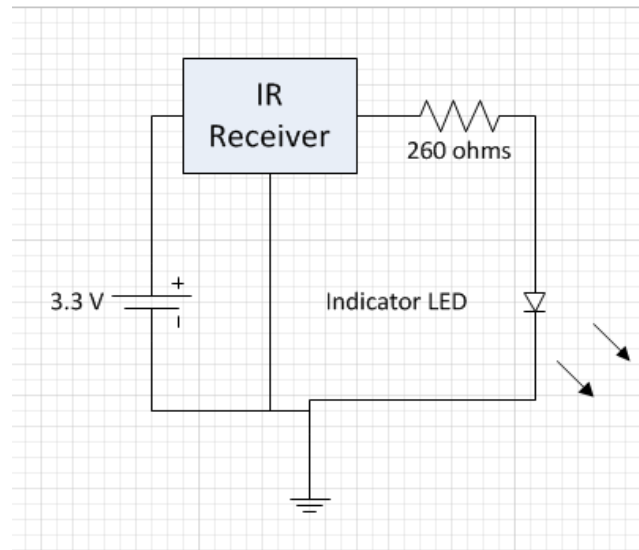

Figure 4.9.6.4.1: IR Receiver Schematic

4.9.6.5 Transmitter Circuit

The TSOP6100 has a forward voltage of 1.5 volts when 200 mA is allowed through. When placed on a 9 volt source, it will need a resistance in series with it to prevent over current.

$$R = 9 - 1.5 / .2 = 37.5 \text{ ohms.}$$

The MSP430 can only source 40 mA at 3.3 Volts, so instead of a direct connection, the MSP430 will control a MOSFET that will act as a switch for the IR LED in the 9V circuit. This is shown below as Figure 4.9.6.2.

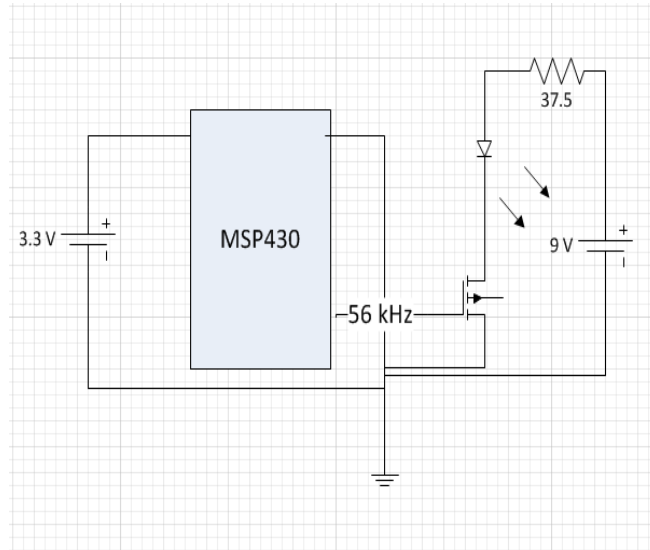

Figure 4.9.6.2
IR Transmitter Schematic

5.0 Design Summary

5.1 Flow Charts

Hardware Block Diagram

The Laser Kart system is based around an MSP430 microcontroller. It will communicate with 4 input devices and 4 LEDs. The inputs are shown below with diamonds and the LEDs are shown below with circles. It will also control a servo via a pulse width modulated signal and the wireless communication system via UART protocol. The power regulator will distribute 3.3V and 5V power to the microcontroller and all of the other systems. Power systems are shown in grey. LEDs are shown in red and green. Photodiode sensors are shown in yellow. Driver inputs are shown in orange. IR systems are shown in blue, servo systems are purple. Wireless systems are tan.

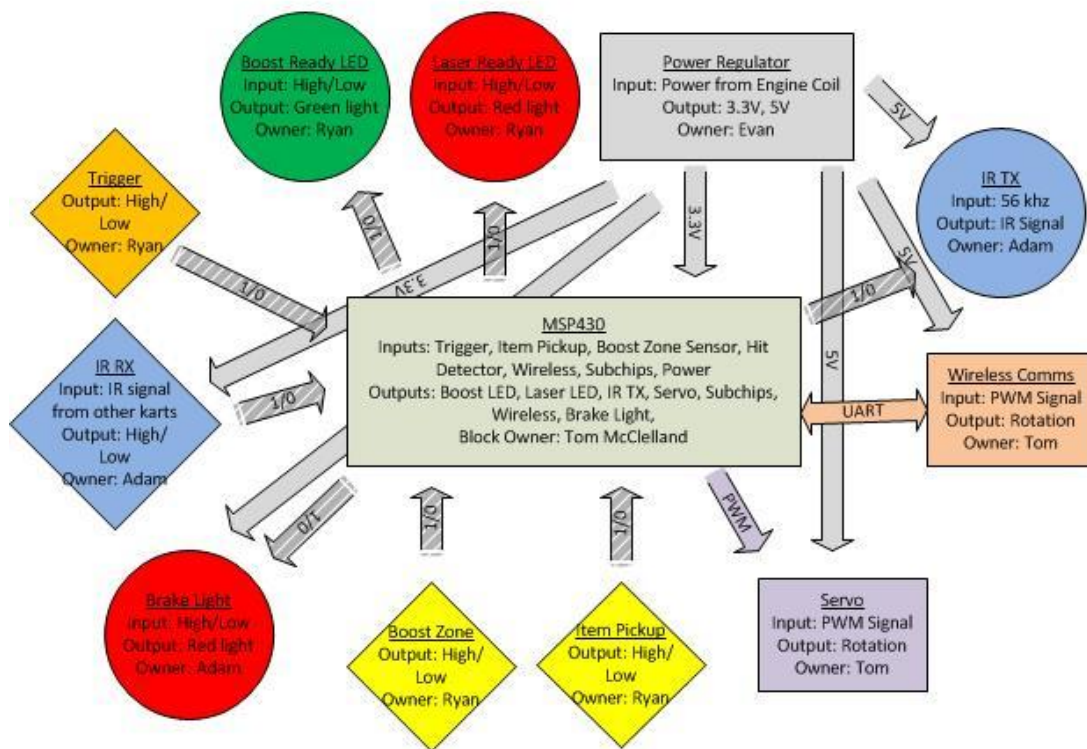

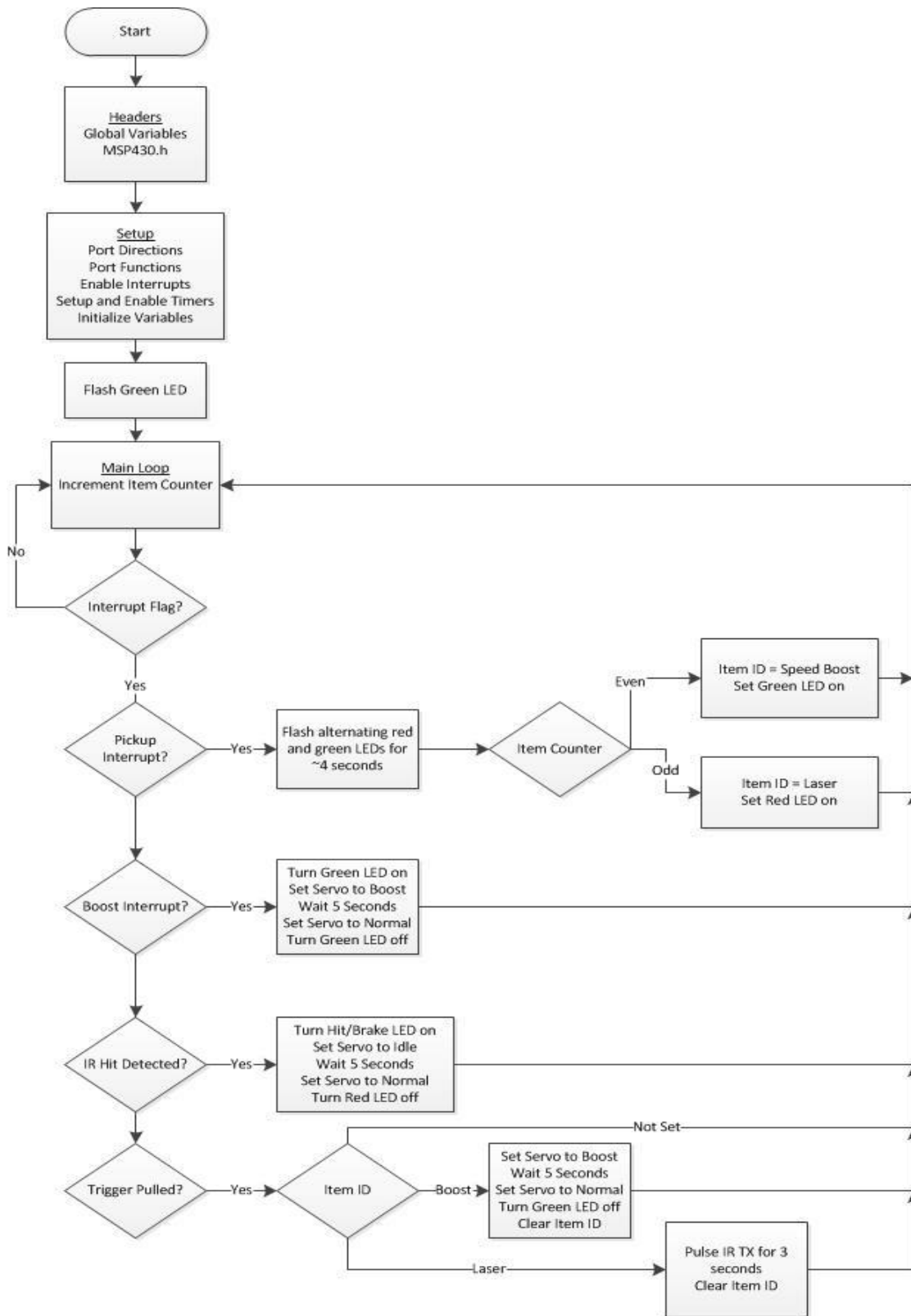

5.2 Hardware Design Summary

5.2.1 Power System

Given the number of subsystems that can be applied to the project, the power systems will need to cover a wide range of possible configurations and requirements. The power system for the laser karts focuses on delivering the necessary DC voltage and current required by each component. The subsystems include the weapons pickup op-amp, MSP 430 microcontroller, IR transmitter and receiver along with any of the optional modules considered such as the LED accessory lighting and in game sound effects. Ideally, all systems are expected to be powered using an AC coil that is stock on each Honda GX270 engine.

The biggest challenge faced when designing the power system is the conditioning of the AC source output of the coil. Special consideration will be necessary when converting this output to obtain a stable signal. The output to the coil will need to be conditioned to a steady DC value that will then be voltage and current regulated as needed by the subsystems that are being powered. The design required to condition the signal produced by the AC coil is the full-wave bridge rectifier, using four schottky or 1N4148 diodes which will be in parallel with multiple capacitors and potentially inductors, depending on the power supply's characteristics, in order to produce a steady ripple voltage. Once the ripple voltage is obtained it will be used as the input to several LDO voltage and current regulators to provide voltage values anywhere between 1.6V to 5V and 240 μ A to 1A. Table 5.1 shows the voltage and current requirements of the main modules in the design.

There are several regulators that meet the requirements of the systems to be powered. The regulator chosen for MSP 430 is the LT3008 series low dropout linear regulator based on the fact that the MSP 430 requires very little power. This regulator does not need feedback protection which is important when considering the AC coil on the Honda GX270 will be changing frequency and amplitude quickly when the throttle is undergoing rapid changes in position.

The regulator chosen for the weapons pickup 2-channel op-amp is the LT3014 - 20mA low dropout micro power linear regulator. This system, like the MSP 430, requires very little power and needs to be protected from any feedback produced by the AC coil which is also a feature of the LT3014.

The use of batteries is a possibility for testing and demonstration purposes. There were several types of batteries that were considered such as lithium-ion, nickel-metal hydride and alkaline batteries. Since the systems each have their own power requirement they could potentially use different batteries. An alkaline battery will be used for the IR Tx/Rx system due to the high power consumption. The MSP 430 and weapons pickup op-amp can be powered by a small lithium-ion battery as well as the other subsystems on the Kart.

The power systems hardware for the optional modules such as the accessory lighting user graphics display and sound effects will be considered on an as needed basis. For now it is only necessary to have the hardware chosen for the core systems.

System	MSP 430	2-channel op-amp	IR Tx/Rx
Vin max	3.6V	5V	5V
Vin min	1.8V	3V	4V
Amps	240 μ A	2.8mA	1A

Table 5.2.1 Voltage and current requirements of each system

5.2.2 Item Acquisition

The Item Acquisition subsystem is simple in concept, but tricky to implement in reality. Through exhaustive research and moderately successful iterations of a working design, the final design of this subsystem will entail choosing phototransistors, a 2-channel op-amp and 2 channel comparator (or 4 channel op-amp), and calibrating them all with the appropriate passive components.

Two Phototransistors must be chosen that will respond in less than 60ms, in the visible light spectrum, to a relatively low energy reflection off of a neon colored marker illuminated by a UV LED. Each of the phototransistors will have a different colored filter (one green, one red) that will allow each to respond accordingly to its matching neon marker.

The op-amp selection is a little more demanding. The Op-amp must be able to operate on a single power supply that is relatively low voltage (5V). Texas Instruments recommends using a CMOS input op-amp for such an application. The TLC272 LinCMOS dual op-amp would be ideal for this system due to its ability to run on a single supply down to 3V and its high input impedance. The single supply set up will need to have a DC biased input to compete with the phototransistor input. This will set a threshold for which there will be an appropriate output given enough light to the phototransistor. The other channel of the op amp will be set up exactly the same but with a different color filtered phototransistor at one input. When exposed to either color, both phototransistors will respond, however, one will have a higher output than the other when exposed to the color that matches its filter, this is where the comparator comes in.

The comparator, which could be a discrete component or 2 more channels of a quad op amp, needs only to limit the final output to one color activation. So in order to do this, each output from the previous stage will go to a V+ from one op amp and a V- on the other op-amp (see fig.). In theory, this should act as sort of an XOR of the outputs from the phototransistor op-amp stage.

Realistically, here are challenges to be met in designing a stable photo-detector circuit. For one, the level of light to be detected is very low, and there is very little time to detect it. Op-amps used in photo-detection need to be frequency compensated due to input capacitances introduced by photodiodes and phototransistors, otherwise output may not be stable enough and could oscillate. Also, a hysteresis threshold may need to be set on the comparator stage, so that any bouncing can be eradicated.

5.2.3 PCB

The MSP430 will be mounted on a printed circuit board along with the power system components. The pins on the MSP430 that are actually utilized by this system will be connected to wire terminals at the edges of the board for connection to the various other modules. The MSP430 will be able to read and control many of the other features directly, but the infrared transmitter and the brake lighting system will require more power than the MSP430 can source from a single pin. Therefore, the printed circuit board will also have two MOSFETs connected to the IR transmitter and the brake lights. There will also be a small LED to indicate that the power is on. The MSP430 itself will be mounted in a 20 pin DIP socket that will be solder to the printed circuit board. Mounting the controller in a socket instead of soldering directly to the board will ease in programming, debugging, and upgrading the system later.

5.2.4 Servo

The kart engine will be controlled by an all metal hobby servo connected to the throttle regulator. The servo will be mounted to a large heat shield that is already in place on the top of the engine. Between Lazer Kart events, the engine will run normally. When something on the Lazer Kart system commands either full throttle or idle, the servo will rotate and either boost the power of the engine or cut the power to idle, depending on the event.

5.2.5 LED Accessories

The LEDs will be placed in various locations on the karts, including on either side of the driver and around the roll bar above the drivers head. The programmable LEDs will be controlled by either the available pins on the MSP 430, the use of I2C or an entirely separate Arduino MCU depending on the requirements, time and budget constraints of the project. The LEDs will perform different lighting displays depending on the event occurring in the game. For example, when a driver is hit by an opponent, the LEDs will flash red for a few seconds, giving the effect that their kart is malfunctioning or if the driver fires their weapon the LEDS will display a cascading effect from back-to-front as though the weapon is being discharged.

5.2.6 IR Transmitters and Receivers

The IR Transmitters and receivers are the main race combat simulator for LazerKarts. They will operate on a 56kHz PWM carrier signal with a wavelength of 940nm. The transmitter will be incorporated into a barrel system mounted on the front of the kart, the receiver will be combined with the braking and hit light system, and mounted on the rear of the kart. Drivers will use the IR lazer system to tag other drivers to facilitate passing during the race. This system will connect to the main unit with removable plugs for easy replacement

5.3 Software Summary

The Lazer Kart system will be controlled by the MSP430. Because the events that make up the game will happen relatively infrequently, the software is largely interrupt based. It will use global variables to keep track of interrupt flags, items picked up, items used, and general counters.

The Main loop on the software program only increments an item counter. Changing the value of this counter every clock cycle allows for randomized item pickup.

As the different sensors and modules of the Lazer Kart system detected events, they will trigger interrupts and the associated interrupt service routine. These are summarized here:

5.3.1 Item Pickup

The photo diode detector is connected to the MSP430 on an input pin. When the voltage on this pin triggers an interrupt, the code will check the value of the item counter from the main loop. It will then flash the LEDs several times and then settle on the appropriate item. That LED will remain illuminated and the ready item variable will be updated with that item.

5.3.2 Boost Pad

When the boost detector has triggered an interrupt, the Boost subroutine will begin. The green LED will be turned on and the servo will command full throttle for 5 seconds. This is about 10% more power than is normally available to the driver. It makes for a fun acceleration and a few MPH increase in speed.

5.3.3 Hit Detected

When the IR receiver detects a signal from another kart, the kart has been “hit” by the “lazer”. The hit kart will illuminate the brake lights and the servo will rotate

to close the throttle to idle for 5 seconds. After 5 seconds, normal speed will resume.

5.3.4 Trigger Pulled

Pulling the trigger will trigger the ISR from the trigger pin. This portion of the ISR will check the status of the ready item. If there is no item ready, the interrupt will be reset and the main loop will resume. If it is 1, the boost routine will be called as described above. If it is 2, the pin controlling the IR transmitter "fire". The IR transmitter transmits at 56 kHz in a specific pattern. This will be described in detail in the IR section of this report.

6.0 Prototype Construction and Coding

6.1 Building the Modules

One goal of the project is that the go karts are easily maintainable. It was expressed by the project sponsor that each kart is already requiring regular maintenance, leaving little time or resources for additional maintenance. To reduce the amount time required to fix or replace any of the modules they can be attachable or detachable, making the modules easy to swap in and out with a working module. The systems that are either located in a specific location on the kart similar to the weapons acquisition sensor or the IR Tx/Rx sensors will be modulated.

6.1.1 Connectors

One way to isolate the modules can be through the use of board-to-board, wire-to-board or wire-to-wire connectors. There are a number of distributors carrying a wide variety of these multi-wire connectors such as Molex. When selecting a connector there are many options such as the number of wire positions available, contact area and thickness, housing material, right or vertical circuit connection.

The weapons acquisition sensors will only needs power and ground running to three different sensors under the kart, so the number of wire positions will be 6. This circuit is very low power, only needing about 30mA of current so the connection area will be minimal. For accessibility, the connector will be located near the PCB. With this in consideration the weapons acquisition sensors only require a wire-to-wire connector as long as it is in close to proximity to the PCB. One connector will be needed for providing power to the PCB from the coil, having two positions for high and ground. The connector will need to be large enough for 14 gauge wire. There will also need to be a connector for the ready-light button on the steering wheel with only 2 positions. There will be a wire-to-wire connector running from the IR Tx/Rx, one coming from the back of the kart (Rx) and the other from the front of the kart's seat (Tx). Wire-to-wire connectors will be used for the LED accessory lighting to the PCB, 1 on each side of the kart. The chosen LED strips only require a VCC and ground wire, so this connector will only need 2 positions as well. Their will need to be a connector for the servo motor that is near the engine block the only requires two wire positions as well. If ZigBee is used this system will also require a connector.

The option of wire-to-board connectors are a possibility but the issue with this approach is that these connectors require a lot of real estate and add more cost to the fabrication of the PCB then does the additional costs of the wire-to-wire connectors. A typical connector is low cost but it should be considered that the modules will be exposed to dust, oil, vibration and water regularly so the best selection of connectors will seal the wires from the elements. A family of

connectors that meets these requirements is the Mizu-P25™ Miniature Waterproof Connectors (Sealed Connectors). Table 6.1.1.1 shows some of the key features of these connectors. Even though the system could operate perfectly without the connectors, they are in fact the best approach to reducing the amount of time it will take to repair the karts, should any of the components fail or get broken.

Certified for IP67 rating	Complete dustproof and waterproof protection
Compact size	Space saving for tight packaging applications
Integral seal stopper feature	Waterproof protection
Spring-beam terminal design	High pressure and small deflection for high-vibration applications
Raised-body male terminal design	Provides polarization to prevent mismatch
Positive locks	Secure mating retention

Table 6.1.1.1 Mizu-P25™ Miniature Waterproof Connector Details

6.1.2 PCB Housing

Due to the exposure to the elements and the threat of being damaged by riders, the use of a durable waterproof housing for the PCB is an important preventative measure. There is a number of off the shelf containers that would be suitable for the PCB. The dimensions of the whole PCB are 3.5 x 2.5 in. One option is to have the box custom manufactured by one of the many companies specializing in this line of work; however, the cost is high. Another option is to purchase an off-the-shelf enclosure. A manufacturer of these enclosures is TEKAM Enclosures®. Customers can specify cases with flat end panels for handheld or portable use, or end panels with integrated wall mounting ears. They are available in sizes from 2.75 x 2.36 x 1.22 to 6.89 x 4.17 x 1.81 in (Extruded Aluminum Enclosures) and come with 2 molded rubber cases gaskets for sealing. There will be a need to drill holes into the casing so that the various connections can be easily disconnected when they need to be replaced. Each hole drilled will have gaskets or some form of sealant to protect the PCB from the elements. An image of the enclosures can be seen in Figure 6.1.2.1.



Figure 6.1.2.1 PCB housing (Extruded Aluminum Enclosures)

6.1.3 Servo Mount

The group considered having a custom mount built for the servo but the quote was out of the available budget so instead the servo mount will be made using multiple layers of sheet aluminum sandwiched together to increase rigidity and strength. Before sandwiching the layers of aluminum together each layer will be worked on separately. Each layer will require a rectangular hole in the center large enough for the servo to slip into. The servo will be screwed down to the sheets of aluminum using small tap con screws, thus connecting the layers of aluminum together. The mount will then be attached to the engine block using bolts.

6.1.4 Weapons/Boost Pickup Sensor

Besides putting the sensors in a convenient location (discussed in the installation section) the sensor underneath the kart should be protected from dirt and debris that could potentially cause the sensor to fail. A solution to this issue is to use a thin sheet of acrylic. The acrylic will also be easily removed. The location of the sensor is near the left side of the kart behind the driver close to the perimeter of the kart so the plastic can be wiped down if any grease or mud from the track gets on it.

6.2 Installation

The LazerKart subsystem modules and sensors will be installed in various locations including the go kart frame, engine block, and steering column. The installation procedure will have to take into account areas that are subject to driver interference (getting in and out of the kart), high vibration, heat from the engine/exhaust manifold, line of sight (for IR subsystem), and under-kart shade (item pickup) among others. The installation of each subsystem will be explained in detail accompanied by pictures to enhance the descriptions.

These preliminary installation descriptions are subject to change once the finalized modules are physically on hand and ready to be mounted.

6.2.1 Throttle Control Servo

The Throttle Control Servo will be mounted onto a bracket that will be fabricated from an 8"x2" aluminum plate bolted through the two mounting arms extending from the engine block as show in fig. The boost spring and the slow spring will be () and () respectively and will the servo arm to the throttle regulator as indicated by the arrows in fig. After shock testing the mount, any necessary steps to increase the stability of the bracket and/or lessen vibrational issues will be taken into consideration.

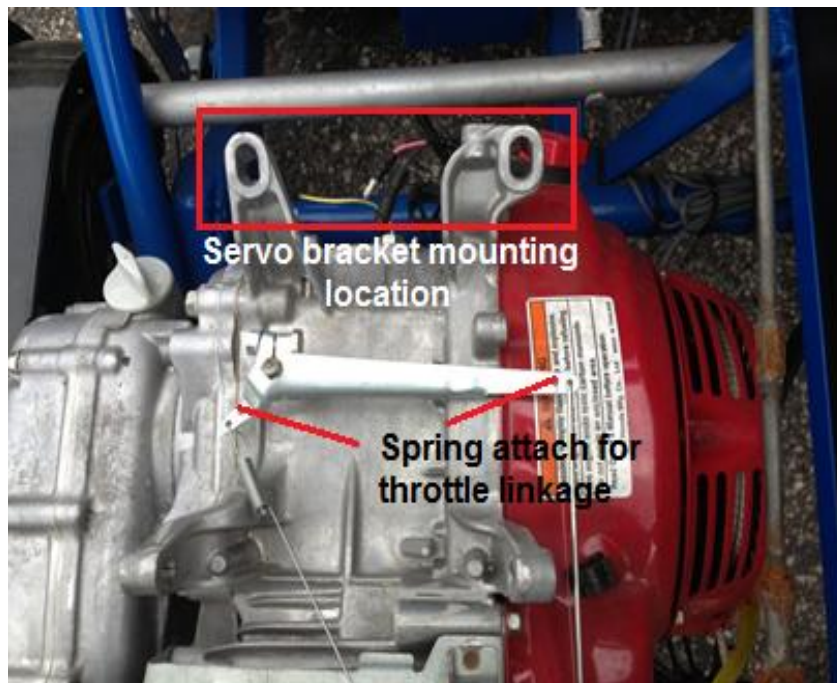

Fig.6.2.1.1: Throttle Control Servo mounting location

6.2.2 LazerKart Main Module

The main module will be housed in a weather-proof box that will be mounted where the existing KARTROL™ unit is located. This is a relatively centralized, easy-to-access location for all of the modules to connect to and no new brackets will have to be fabricated. Although shock-testing will be performed on all modules, the fact that the existing KARTROL system has withstood the abuses of the go kart track is a testament to the viability of this location as suitable for the LazerKart Main Module. However, it is notable that the KARTROL module can only be replaced if the LazerKart main module will incorporate the ZigBee

communication system that will effectively allow for overriding the control of the throttle from a remote location by the staff of the go-kart venue. In the case that ZigBee is not implemented, then the LazerKart main module would be mounted adjacent to the KARTROL module and secured in a similar fashion.

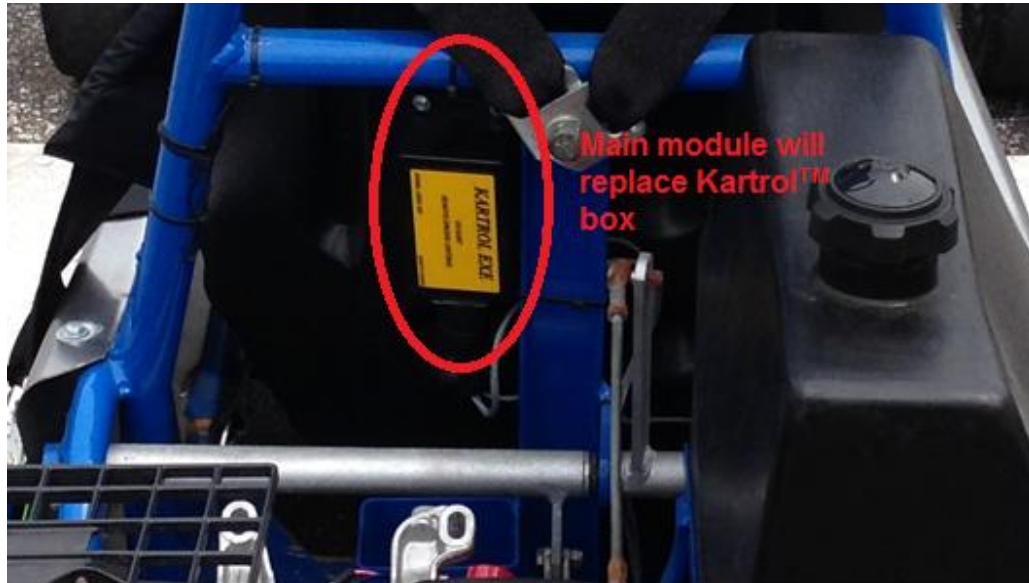

Fig.6.2.2.1: Main Module mounting location

6.2.3 Item Pickup Sensor

The Item Pickup Sensor will be remotely located, from the main module, into the area on the go kart frame shown in fig. The sensor itself will need to be shielded as much as possible from ambient light, so initially, the idea was to mount the sensor directly underneath the seat, which is still a viable option, however, this location, which is just behind the seat will require less wire length. The sensors will mount through an 8"x8" aluminum plate that will be bolted to the squared area.



Fig.6.2.3.1: Item Pickup Sensor mounting location

If the preceding location doesn't comply with the ambient light requirements, then the alternative location would be under the aluminum diamond plate floor base of the go kart. The area of this location can be seen beneath the steering wheel in fig.

6.2.4 IR Transmitter/Receiver

The IR lazer tag receivers will be either mounted up high on the backing plate of the roll bar or bracketed on the roll bar just below the plate on the go kart. This way, the receiver will be easier to hit with the IR transmitter. The roll bar plate is approximately 1/8" thick, so a mounting solution would be to drill 2 or 4 holes through it and directly bolt the module onto it, secured with nuts and washers.

If the other option is pursued, then the module could be bolted onto two adjustable clamping brackets that would fit around the 1.5" diameter roll bar. The connecting wires from the sensors to the Main Module will run along the length of the roll bar, sheathed in matching blue 3/8" heat shrink tubing and secured with blue zip tie wraps.

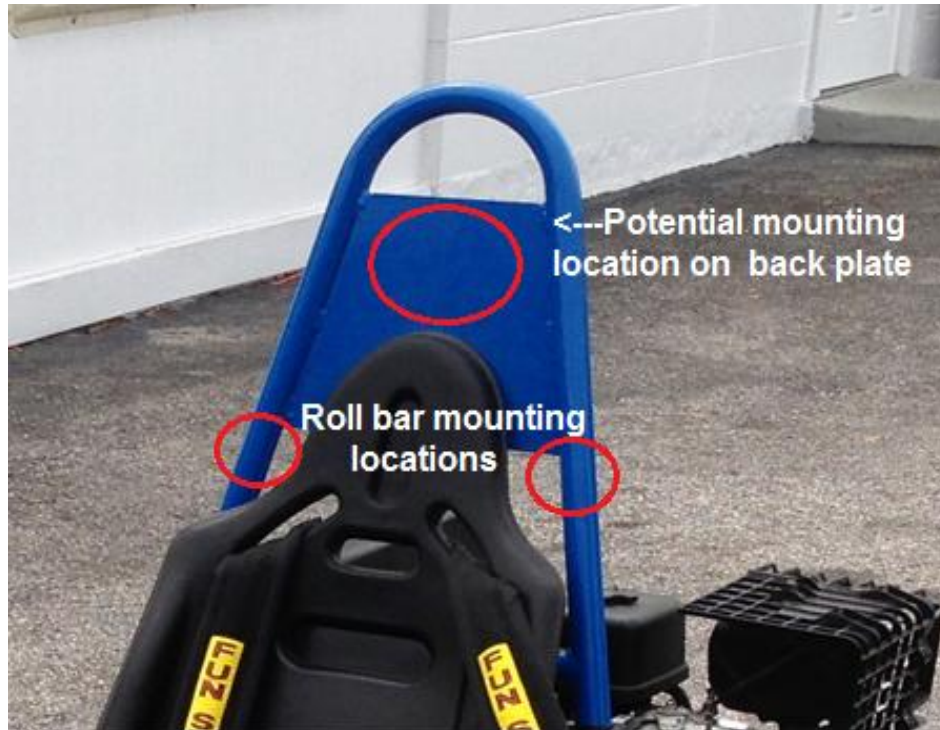

Fig.6.2.4.1: IR Receiver mounting location

6.2.5 Ready Light/8x8 LED Display

Initially, the LazerKart system will only have two ready lights to indicate whether a boost or an item is activated. Those lights will be installed onto the steering column in a fixed position via a metal bracket secured around the diameter of the column or mounted onto the steering wheel itself through the existing holes in the center (behind the safety cushion). The connecting wires for the lights will share the same heat shrink tubing as the trigger buttons and will be zip tied along the frame until it reaches the Main Module.

The 8x8 LED display will have to be mounted in the fixed position, as it will be difficult to view if it is turning with the steering wheel. The mounting solution may require a custom enclosure or dashboard-like covering that prevents light from washing out the display. This covering will have to mount securely, with minimized vibration to the steering column. A mockup of where the 8x8 matrix will be mounted can be viewed in section (), figure ().



Fig.6.2.5.1: Ready light mounting location

6.2.6 Trigger

The item/boost trigger mechanism or “fire button” will be located on the portion of the steering wheel where the thumbs tend to naturally rest. It will require an aluminum bracket that will be mounted via existing through-holes on the steering wheel grip area. Two redundant buttons will be installed in such a manner, one on each side of the steering wheel. All connecting cables or wire will be heat shrink wrapped and zip tied along the steering wheel and down the steering column. These wires will travel along the frame, zip tied every 6-8” until they meet at the main module trigger input.



Fig.6.2.6: Trigger mounting location

6.2.7 Brake light/Stop Lamp Switch

The main brake light would be incorporated into the module for the IR receivers on the roll bar. The signal for the brake light will come from one of two places: a stop lamp switch which will be located behind the brake pedal or on the throttle deceleration arm. For now, we will assume that it will be located beside the brake pedal.



Fig.6.2.7.1: Brake Light mounting location



Fig.: Stop Lamp Switch mounting location

6.2.8 Accessory Lighting

The accessory lighting LED strips will need to be located in such a fashion as to minimize the chances of a driver accidentally making physical contact (i.e. kicking) with them when entering and exiting the kart. Ideally, the LED strips that activate with the firing of a lazer would run along the side rails (fig.) of the kart so they would be visible to the driver, however that may be a bad location due to the traffic of drivers' feet entering and exiting the kart and brushing up against them. To alleviate this, the LED strips may need to be laid under a thick protective clear plastic strip (similar to rope light) that could take the abuse

Like all the other modules, the wires will be concealed within heat shrink tubing and will hug the frame with zip ties.



Fig.6.2.8.1: Accessory light mounting location

6.3 Software Development

Complex embedded software is best written incrementally. When actually developing this project, the code will go through several iterations that get increasingly complex. Lower level functions should be developed and tested before additional functionality is added to the code. To test the code, a small testing platform will be used.

6.3.1 Testing Platform

Because most of the software development will take place away from the actual project kart, there needed to be a way to quickly test and troubleshoot the software code. The MSP430 Launchpad comes with two LEDs, but that is not sufficient for testing complex code. For this, a small development board will be used. On this testing board, 6 LEDs will be mounted, each with their own current limiting consisting of 6 LEDs with current limiting resistors will be used. The LEDs have a forward voltage drop of approximately 2 volts and the MSP430 uses a 3.3 volt signal as a logical high. The LEDs have a current limit of 20 mA, To find the proper resistor value for current limiting:

$$V = I * R$$

$$(V_{msp} - V_{led}) = I * R$$

$$(3.3 - 2.0) = .020 * R$$

$$R = (3.3 - 2.0) / .02$$

$$R = 1.3 / .02$$

$$R = 65 \text{ ohms}$$

As 65 ohms resistors are not widely available, any value from 65 to 100 may be used. A higher resistance will mean lower current. The LED would not glow quite a brightly, but that isn't a concern for testing, we are just trying to verify if pins on the MSP430 are going high or low at the proper times.

In addition to the 6 LEDs used for testing, we will use another board with 3 small buttons. These will be single pole, single throw buttons that will be used to simulate the inputs to the Lazer Kart system. The three simulated inputs will be the driver's trigger, the item pickup, and the hit detector. As discussed in the software section, the interrupts for these three actions are triggered by a low to high level change on the input pins. Therefore, these buttons will be connected with a pull down 10k resistor as shown below in Figure 6.3.1.1.

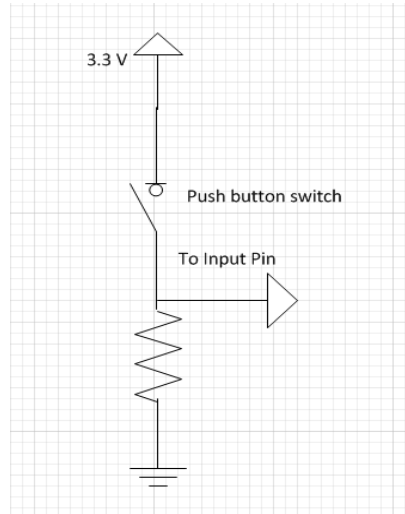

Figure 6.3.1.1

Pull Down Resistor for Trigger Input

The MSP430 Launchpad development platform is equipped with male headers for each pin. To ease development, each LED and switch on the testing platform will be connected to a short length of wire ending in a female header. This will allow for the easy connecting of the testing platform to the Launchpad and speed development. In this way, all interrupts, inputs, and outputs can be tested in the lap before being taken to the kart for final testing.

As mentioned above, writing the code will be done incrementally. Each function will be tested on the test platform before additional functionality is added to the code. First, the setup routines will be written and basic port direction will be verified. Then, the interrupt setup code will be written and the interrupt service routines will be written. To test this, the test platform will be connected with the push buttons connected to the input pins for trigger, item pickup, and hit detect. The LEDs will be connected to the item indicator pins, the brake light pin, and the IR transmitter pin. Each button will be pressed and each interrupt and function will be verified. Then, once the interrupts are known to be working, Pulse Width Modulation for the servo control can be added. This will involve setting up Timer A and adjusting CCR2 to set different angles for the servo. Finally, the IR transmitter will need a 56 kHz pulsed signal. This will be configured using software delays for toggling the IR TX output pin. This will need to be tested using the hand held IR testing equipment described earlier in this report.

Once all the software code for all the different functionality has been written and tested on the test platform, the MSP430 can be loaded with the complete code and taken to the actual kart for installation and final testing.

7.0 Testing

7.1 Subsystem Tests

7.1.1 Item Pick-up Sensor Testing

Testing of the item pick up sensor is a simple format: drive the go-kart over two different colored markers and make sure the sensor differentiates between the two with no error. The difficulties will lie in achieving success in the testing. The testing phase must be done during the day, and with varying outdoor temperatures. Several Ideas have been proposed to test the functionality of the item pick up sensor system. Since the sensor system will utilize a UV black light LED, the markers need to be fluorescent. The first proposed idea is to apply Duck® brand fluorescent duct tape rectangles to the pavement. These pieces are - in size and will be combined accordingly to driver visibility and ease of pick up sensing. The go kart will be driven at full speed over the marker and at varying slower speeds:

- At full speed, the sensor needs to be able to react quickly enough to get a signal to the microcontroller
- The sensor needs to be tested at slower speeds to ensure that both color triggers don't go high at the same time. This is due to susceptibility of phototransistor to saturation.

While sufficient for mere testing, the inherent problem with this method is that the duct tape will inevitably succumb to the elements, therefore a different method was considered for venues that might make LazerKart more permanent. There are various manufacturers of fluorescent paints and "black light" paint that is highly reactive to UV light. While it may or may not be desirable to paint the pavement of a racetrack, the group considered painting large colored squares on a dark mat that could be placed across the track. The mat would have a tapered edge so there wouldn't be an abrupt speed bump effect when driving over it, and it would run completely across the track and be secured off track so the mat won't be displaced or fold over itself.

In addition to sensing the markers, the phototransistor circuit will need to be calibrated for ambient light leakage due to daytime operation during these trials. Positioning of the sensors on the kart underside will also be of importance during these tests.

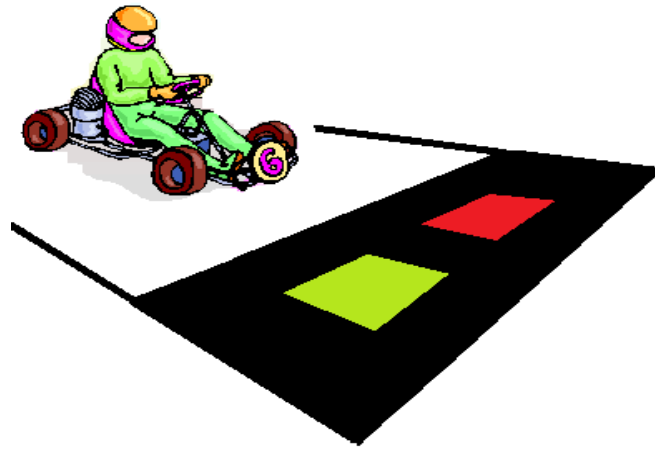

Fig. 7.1.1.1: Item pickup/boost zone mat with fluorescent markers

7.1.2 Boost-zone Testing

The Boost zone testing phase will address several calibration procedures required to allow for a noticeable, yet controlled speed increase in the go kart. The first issue is sensing the boost-zone, then determining an adequate throttle threshold, and lastly, adjusting the duration of the speed boost.

The sensing portion of the Boost-zone tests will be similar to the item pick up tests. A specific color, probably yellow or green will be chosen for the Boost-zone marker. Whichever method that works the best for the item pick-up, whether it be the duct tape or the painted mats will be the same for the Boost-zone.

The donor go kart is throttle-limited by an adjustable nut and bolt “stopper” that is placed behind the gas foot-pedal. With the stopper in place, the top speed is roughly 17 mph. The stopper was removed completely to determine if speed gains were noticeable. While top speed wasn’t greatly improved, the acceleration from the “stopped” throttle point to the unlimited point was very noticeable. This will allow for an enjoyable speed boost even at full throttle. However, this was done purely on speculation and guessing with one’s foot. The true test will come when the servo physically pulls the throttle to the desired position from the limited threshold. The servo will be linked to the throttle by a spring. Pre-emptive measurements were taken as to determine spring length, however, these trials will be an opportunity to test varying spring strengths and lengths to determine the optimal choice.

Lastly, the duration of the speed boost will need to be adjusted, however, these adjustments need only be preliminary. The best way to determine whether a speed boost is too long or too short will be in an actual play test with other karts.

7.1.3 Microcontroller Testing

Once assembled and installed, one of the most important areas to be tested will be the microcontroller. It controls nearly all of the functions of the Lazer Kart system and must be tested thoroughly for both normal operation and resistance to anticipated potential failure modes. Some of these tests will be repeats of individual system tests, but are necessary to ensure the system is working properly as a whole.

7.1.3.1 Item Pickup

Purpose:

The item pickup subroutine is the first step in the software process. It is important to make sure that this routine is reliably being run when an item pickup indicator is driven over.

Procedure:

To test the item pickup ability, drive the kart over an item indicator at maximum speed.

Expected Results:

The red and green item lights should alternatively flash and then settle to a single light. It should select a Boost roughly half the time and a Lazer half the time. Do at least 8 tests at various speeds and make sure at least 2 items are selected from each item.

7.1.3.2 Boost Item

Purpose:

Once an item has been picked up, the next step in the Lazer Kart process is to use it. The two items will be tested individually, starting with the Boost Item.

Procedure:

With a Boost Item ready, depress the trigger. Static testing of this should first be done with the kart on jack stands.

Expected Results:

The kart should noticeably speed up for 5 seconds and then return to normal speed. Verify the servo rotates to 45 degree counterclockwise for 5 seconds and then returns to neutral position.

7.1.3.3 Lazer Item

Purpose:

The other item to be tested will be the Lazer Item.

Procedure:

Testing the Lazer will require the use of the Handheld IR Testing Unit. The Lazer will be tested both statically and while the kart is moving. Details of the IR system testing will be described in full later in a following section.

Expected Results:

If the IR receiver is picking up the IR transmission, then the microcontroller's function is verified to be working.

7.1.3.4 Boost Pad

Purpose:

Because the Boost Pad is attached to a different pin and calls a different subroutine than the Item Pickup Pad, it should be tested individually.

Procedure:

To test the Boost Pad routine, the kart will be driven over a Boost pad at full speed.

Expected Results:

The kart should speed up for 5 seconds and then return to normal speed.

7.1.3.5 "Lazer" Hit

Purpose:

Testing being hit by another driver's lazer incorporates IR testing with the microcontroller. Here we test them working together.

Procedure:

Begin by activating the IR transmitter in the handheld unit while pointing at the kart. This should first be done with the kart on jack stands and with the IR transmitter at a distance and angle as described in the Specifications section. Once proper static operation has been verified, repeat the previous steps while the kart is driving away at 3 different speeds ranging from coasting to full speed.

Expected Results:

The microcontroller should detect the IR signal, turn the brake and hit lights on, and rotate the motor control servo 45 degrees clockwise for 5 seconds before returning to neutral and turning off the brake and hit lights.

This completes the Normal Operations testing.

7.1.3.6 Possible Failure Causes

7.1.3.6.1 Vibration and Loads

Purpose:

Lazer Kart is designed to be a rugged, dynamic system that can take the abuses inherent to tourists and teenagers driving go-karts. This ruggedness will need to be verified before deployment.

Procedure:

After full installation, the kart should be driven as aggressively as possible to simulate the actual operating conditions the system will be used in. A series of full power accelerations followed by slamming on the brakes to a full stop will test linear durability. The tracks these karts will be driven on are very curvy, so a series of sharp turns at full speed should be made in alternating directions to try to shake the system loose. Next, combining rapid acceleration and deceleration with sharp turning will test the limits of the system. Finally, driving the karts over a bumpy road will simulate rough track conditions that may be encountered.

Expected Results:

Areas to inspect after this test include all of the solder joints on the PCB as well as the cable connections connecting the parts. After all of this abuse, the whole system should be re-tested as described in the Normal Operations Testing section above.

7.1.3.6.2 Shock

Purpose:

In addition to harsh driving conditions, drivers will occasionally hit something. This may be the sidewall of the track or another kart. For safety reasons, we will not recreate full speed crashes. Our goal is not to test the structural integrity of the kart to failure. However, abrupt stops by bumping into a barrier at moderate speed will be done to ensure survivability of the Lazer Kart system and identify any weak points in our mechanical connections.

Procedure:

Abrupt stops by bumping into a barrier at moderate speed will be done to ensure survivability of the Lazer Kart system and identify any weak points in our mechanical connections.

Expected Results:

Areas to inspect after this test include all of the solder joints on the PCB as well as the cable connections connecting the parts. After all of this abuse, the whole system should be re-tested as described in the Normal Operations Testing section above.

7.1.3.6.3 User Damage

Purpose:

Another type of shock that can be expected to be encountered is going to be caused by the operator's limbs. Excited drivers climbing in and out the karts are bound to kick, step on, bump, and knock with their arm any possibly exposed component.

Procedure:

To test for this, the driver's dashboard, external IR sensors, and the servo mount will be tested by kicking with moderate force to ensure secure mounting.

Expected Results:

After all the shock tests are done, the whole system should be re-tested as described in the Normal Operations Testing section above.

7.1.3.6.4 Water

Purpose:

It is the operator's policy to discontinue kart races in the event of rain, but this being Florida, our system will eventually get wet.

Procedure:

To test weatherproofing, 8 oz. of water will be poured onto each component of the system from above to simulate rain.

Expected Results:

After the rain test, the system will need to be completely retested as described in the Normal Operations Testing section above.

7.1.4 Servo Testing

Purpose:

As the only moving part of the Lazer Kart system, extra testing should be done on it to verify proper operation. The servo is moved by both Boost events and Idle/ Cut events from IR hits from other karts.

Procedure:

As such, both directions should be tested. Boost and Cut movements should both be tested at idle, half power, and full power. This is because the return springs on the engine governor will be applying different forces depending on the throttle position. Finally, tests should be done where both Boost and Cut signals are applied when the kart is at different speeds. These tests will be done at a full stop, middle speed, and at full speed.

Expected Results:

The servo should set the engine to the desired throttle position regardless of the kart's speed or the driver's throttle position.

7.1.5 IR TX/RX Testing

The IR LED tagging system is designed to facilitate the combat aspect of the racing game. For best effect it will be necessary to calibrate the transmitters and receivers in a way as to make the race enjoyable and challenging. Typical lazer-tag systems employ a lens system to produce narrow high power beams that can score hits over 200 yards away. For the Lazer karts game purposes, this range is unnecessary, and potentially detrimental to the game play. Ideally the maximum registerable range will be on the order of 100 feet.

In order to accomplish this goal an off kart version of the tagger and receiver will be built and a variety of lenses will be used at different ranges. The receiver will be fixed to a vertical surface, and the tagger will be fired at the receiver several times, while increasing the distance from the receiver. Once maximum range is achieved the tagger will be tested to determine the accuracy needed for a hit. This process will begin with the tagger in a PVC tube with no lens, in order to establish a baseline, and then various lenses will be swapped out, and the process repeated.

After the initial run through of the lens testing, the entire process will be repeated for different lighting conditions. Direct sun lighting is the condition most likely to cause problems with the lazer system. The chart in Fig 7.1.5.1 below will be used to determine the idea setup for the transmitter to be used for single kart testing. If it is determined that changes need to be made during single kart testing, the chart will provide guidance.

		No Lens	Lens A	Lens B	Lens C	Lens D
Indoors	Distance					
	Accuracy					
Direct Sun	Distance					
	Accuracy					
Over-cast	Distance					
	Accuracy					

Fig 7.1.5.1

7.1.6 Power Systems Testing

The power system will require multiple stages of testing. Simulations can be run on the circuits but they only provide results of an ideal environment and operating conditions. Some of the variables and conditions that will be seen in an actual game of Lazer Karts include high ambient temperature, moisture, vibrations and long term wear and tear. Although some of these conditions cannot be considered when designing a prototype they are still worth noting, as they will all have an impact on the longevity and performance of the overall system. These tests will be run multiple times in a sequential manner as needed while component values such as resistances and capacitances are changed

7.1.6.1 AC Coil Testing

Purpose:

The first stage of testing is determining the characteristics of the signal produced by the Honda engine's AC coil. The following steps will be taken when analyzing this signal.

Procedure:

- Measure peak voltage value while at idle
- Measure peak voltage value while throttle is open
- Obtain frequency of AC signal at idle
- Obtain frequency of AC signal while throttle is open
- Record any unexpected characteristics of AC signal i.e. shape and/or changes in signal produced due RPM of engine
- Record all values and potential causes for unexpected signal characteristics
- Save images of signals displayed on oscilloscope for each scenario

Expected Results:

When testing the AC coil signal it would be ideal if the signal produced turns out to be a sine wave for all throttle positions. It is also expected that the frequency has a 1:1 ratio with the RPM of the engine, i.e. when the throttle is in the idle position with a rate of 1200 RPM the frequency of the coil is around 20 Hz and when the RPM of the engine is high around 3200 RPM the frequency of the signal is around 50Hz.

Note: It may be necessary to do some research on the internal workings of the Honda GX270 engine's AC coil if the signal measured shows any unexpected characteristics.

7.1.6.2 Rectifier

Purpose:

Measure the output of the full-wave bridge rectifier circuit when connected to the output of the AC coil.

Procedure:

- Apply power to input of rectifier circuit
- Measure output with respect to “low” node while at idle
- Measure output while throttle is fully open
- Check output with and without coupling capacitors to understand rectified signal and ripple voltage individually
- Run tests with several capacitor and load resistance values to obtain optimal ripple voltage
- Save images displayed on oscilloscope for further analyses
- Record and provide potential explanations for results obtained
- Obtain results when using different the 1N4148 diodes and Schottky diodes

Expected Results:

The output of the rectifier with and without the coupling capacitors should be a rectified signal and a rippled DC voltage respectively. The DC peak-to-peak value of the ripple voltage output should only vary slightly when the throttle position is changed from idle to fully open. The rectified signal peak value should be higher when using Schottky diodes than when using 1N4148 diodes do to the lower forward bias value of the Schottky diodes.

7.1.6.3 Regulators

Purpose:

This test will be run to determine the output of the various regulator circuits built. Each regulator will be tested without connecting the actual component it is design for as this is a precautionary step taken to avoid destroying them. Instead a load resistance will be used that is approximately the operating resistance of each device.

Procedure:

- Connect the input pin of each regulator, with appropriate capacitors and adj. resistors necessary to simulate device, to the output of the full-wave bridge rectifier.
- Measure the output voltage and current of each regulator
- Find the experimental resistance needed to obtain desired voltage and current while adjusting the throttle position
- Record all results and DC values displayed on oscilloscope

Expected Results:

When running tests on the regulators it is expected that the DC voltage and current are the ones required by each subsystem. These values should be approximately the values seen in Table 4.1

As stated before these tests will need to run multiple times, potentially requiring large amounts of research between each test to redesign a circuit, specifically the rectifier, or choose a different regulator to obtain the desired results. The power system is particularly unpredictable due to the wide ranges of values produced by the AC coil, making the testing process time consuming and tedious. This system will undergo further testing when it is connected to the actual devices it is designed to power to ensure that these components operate as expected. Additionally, the systems will also be tested with the discussed batteries to determine the amount of time between charges and operation performance.

7.1.7 Optional Module Testing

7.1.7.1 Accessory LEDs

Before the LEDs can be installed it is important that they function properly. Testing the LEDs will involve two stages; determining how many LEDs can be on at once and how it will affect the power output of the Honda GX270 AC coil and other components; making sure that the LEDs respond to the microcontroller for the correct function and they show the correct display.

Stage 1

Purpose:

The first test will be run to determine how much power the LEDs will be consuming when they are at their dimmest and brightest.

Procedure:

The LED strip is spec'd to have a max current draw of around 1.8A. The light displays for lazer karts will only need short intervals of maximum current draw if at all. After the software has been completed it will be modified to test the LEDs. One test will turn a single LED on while the current is measured. Another test will be performed to measure the current while all the LEDs are lit. Several intermediate programs will be written to measure the amount of current when the number of LEDs increases or when all of them are adjusted from off to a brightness value of 255. The current values will be multiplied by the 5V operating voltage giving a range of power consumption. These values will be plotted and added to the maximum power consumption of the other modules, then subtracted from the maximum power output of the AC coil. By collecting this information it

will be easy to calculate the maximum number of lights that can be on at any given moment based on the “worst case scenario” or when all modules are drawing maximum current at the same time.

Expected Results:

When testing the strips it is expected that they will not draw too much power when all LEDs are lit simultaneously. The maximum power output of the AC coil is around 75W and just one LED strip has a max power consumption of 9W allowing for multiple strips to be used, reserving batteries as a backup plan.

Stage 2

Purpose:

The LEDs are supposed to display specific patterns for the three functions of the kart. This test will check for the correct functionality of each lighting display based on the signal sent by the microcontroller.

Procedure:

After uploading the code to the microcontroller, the lights will be tested for correct functionality when; a weapon is acquired; a driver fires their weapon; the kart is hit by an opponent.

Expected Results:

- Driver fires weapon: All LEDs should light one at a time from back to front down both sides of the kart multiple times for the correct interval of time.
- Kart hit by opponent: The lights display a series of red flashes for the correct interval of time.
- Driver acquires weapon/boost: The lights will go from off to fully lit, slowly going through the different brightness values from 0-255. The color of the lights will be specific to that kart.

7.1.7.2 Audio Components

Before installing the audio components it is important that they function properly. Testing the sound effects will several steps. The testing will be very similar to the steps taken when testing the LEDs since both functions are going to be called by the microcontroller at the same time. Determining how loud the speakers are with respect to the Honda engine is also an important factor to consider. It will be necessary to know how much power will be drawn from the Honda GX270 AC coil and how this will affect other components. Finally it is important that sound effects respond to the microcontroller for the correct corresponding events, weapons/boost pickup, using the weapon/boost and being hit by an opponent.

7.1.7.2.1 Power Consumption

Purpose:

The first test will be run to determine how much power the speaker(s) will be consuming when either using the speaker at full volume or the suggested on-kart headphones at full volume.

Procedure:

Using the multi-meter, a range of current values will be measured while adjusting the volume. Two separate tables will be made, one for the current values measured using the 3 inch speaker and one for when using the headphones. These values will be multiplied by 3.3V (operating voltage for the audio module) to get an estimate of how much power it requires. As done when testing the LEDs the wattages will be added to the power consumption of the other modules to obtain a “worst case scenario”. These values will be subtracted from the maximum power output AC coil to determine if batteries will be needed.

Expected Results:

When testing the speakers it is expected that they will not exceed the power output of the AC coil, which is around 75W, when operating simultaneously with the other function based modules including the LED, IR Tx/Rx.

7.1.7.2.2 Sound Effects

Purpose:

The speakers are supposed to play the .wav files when one of the three functions of the kart is processed. This test will check for the correct functionality of each sound based on the signal sent by the microcontroller.

Procedure:

After programming the microcontroller, the speakers will be tested for correct functionality when; a weapon is acquired; a driver fires their weapon; the kart is hit by an opponent.

Expected Results:

- Driver fires weapon or acquires boost: speakers should play chosen sound effect i.e. “firing lazer”
- Kart hit by opponent: speakers should play chosen sound effect i.e. “malfunction” or “powering down” effect
- Driver acquires weapon/boost: speakers should play chosen sound effect i.e. “charging lazars” or “powering up” sound effect

7.1.7.3 No Bumping Testing

Purpose:

As mentioned in the No Bumping section, the Bump Detecting subsystem will consist of an accelerometer, a comparator, and a voltage divider as shown below in Figure 7.1.7.1.

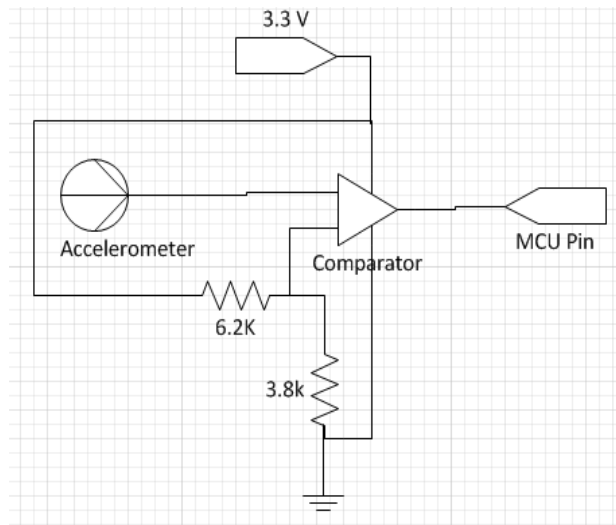

Figure 7.1.7.1

As discussed in the No Bumping section, an “x” g deceleration will be indicated by $1.65 - (.19 \times x)$ Volts on the accelerometer's output. We are estimating that the force of a bump will be around $-2g$. This could be wrong and will need to be tested.

Procedure:

To test this, one kart will be driven forward at full speed, followed by a second kart with the No Bumping system installed at set to detect a force greater than $-2g$. The kart to do the test bump will follow at a distance of 10 feet. From observing kart races at Fun Spot, we determined most following is done at or around this distance. Then, the driver of the first kart will suddenly idle the engine and coast by taking his foot off the gas pedal. The second driver will continue at full speed into the back of the first kart.

Expected Results:

If a bump is not detected, the resistor values will be adjusted so that the interrupt is triggered by $-1.5g$ and the test redone. This will continue until we find a value that reliably detects bumps at reasonable collision speeds.

7.2 Single Kart Tests

Once the tagger setup has been chosen, the single kart tests will take place. The goal of this will be to determine optimum placement of the added components, and will be the first test of a fully functioning system.

7.2.1 Transmitter / Receiver location

The transmitter will be first located centered on the front chassis bar. This location should prove ideal, as it is centrally located and forward of the gas and brake pedals as shown in Fig 7.2.1.1 by the green rectangle. During driving, attention will be paid to foot location relative to the transmitter, and testing to determine ease of contact with the transmitter. It is likely that while some contact may occur, it will be lessened by this location. Also in need of testing will be the angle of the transmitter, as it will be located lower on the kart than the receiver located where the red oval is. The kart will be driven while the receiver on the hand held unit is fixed to the appropriate height difference.

While there are no anticipated problems with the location of the transmitter and receiver, it is best to resolve any issues that occur before mounting the system on multiple karts. The hand held unit will be vital in determining the playability of the game. Distance and accuracy for hits will be tracked. If these locations prove unworkable, alternate testing will be done.



Fig 7.2.1.1

7.2.2 Photo-detection Location

The location of the photo detection sensors will prove critical to the success of the game. Reliable item and boost zone recognition will enhance the game play. Ideally, the sensors will be placed under the forward part of the kart, allowing the driver to have a better sense of the area needed to drive over in order to get the item or boost. The location of choice is shown by the green oval in figure 7.2.2.1. Alternate locations are shown by red ovals.

For the single kart trials, painted mats will be placed on the ground and crossed at varying speeds by the kart. A success rate of greater than 95% at all speeds will be sought. The extensive testing of this part will also test the durability of the sensors to the road conditions. Attempts will be made to approach the mats on straight roads as well as while making sharp turns. The undercarriage of the kart will provide some protection, and if damage is occurring to the sensors, a special housing will need to be devolved based on the results of the testing.

With the expectation that the project is going to be produced for commercial use, durability of this part is crucial, as it is a key aspect of the game. With this in mind, a significant portion of play testing time will be devoted to it. Once a suitable location and housing is determined, it can be replicated for use in multi kart testing.



Fig 7.2.2.1

7.2.3 Triggers and Item Lights

The main point of interaction for the driver will be the triggers. The trigger needs to be durable and easily accessed. As can be seen in figure 7.2.3.1, the ideal location for a thumb mount trigger would be just outside of the protective padding on the upper bar of the steering wheel. The locations of the thumb buttons are marked in red. Alternatively, a gun style finger pull trigger could be mounted lower down on the sides of the wheel, as shown in green. An extra effort will be made to expose the triggers to non-typical levels of torque, to ensure their durability.



Fig 7.2.3.1

The item lights will be mounted to the rear of the steering column, as indicated in green and red on figure 7.2.3.2. This location should keep the LEDs mostly free from driver interference, yet still be highly visible. For testing purposes, attention will be paid to the accuracy of the item lights, which will also tie into the pickup testing section of the single kart testing. An effort will be made to dislodge the lights, to simulate treatment by drivers.

The durability again will be a key part of the testing of these parts of the system, specifically since these are the main contact points between the drivers and the game. Failure of these parts will render the kart unable to participate in the races, and excessive downtime is unacceptable to the commercial viability of the game.



Fig 7.2.3.2

7.2.4 Speed Control Testing

The throttle linkage portion of the single kart testing will be tied into all of the preceding tests. Because this is not a part of the system that the driver has much contact with, durability testing will be limited to mechanical workings of the servo system. Attempts will be made to overwork the servo by continuously engaging the speed boost and by registering hits on the receiver. Much of this testing will occur in tandem with the item pick up and transmitter/receiver testing. One major physical test will be the ability of the mounting unit to hold up under real world conditions.

Once the kart has been shown to operate correctly and over a long period of time, a second kart will be acquired and a new phase of testing can begin. Multi kart testing will be required to develop a working system.

7.3 Multi Kart Testing

Multi kart testing will allow the development of the game play mechanics and allow fine tuning of the systems. Two kart testing followed by four kart testing, and if successful a full 16 kart game implementation.

7.3.1 Two Kart Testing

The main focus of two kart testing will be laser acquisition and system durability when subjected to the inevitabilities of bumping during the racing. Two kart testing will take place off of the track, again with painted mats for item pick up and boost zone testing. This is also where rough tuning will be done to the speed boost duration timers, as well as weapon length timers and throttle cut timers. Ideally any bonus should allow a clean pass, and different scenarios will be observed. Also critical is to ensure that all karts are being affected by the bonus's in the same manner. Care will be taken to ensure that all examples of the kart are as closely matched as possible.

The laser systems will be fine tuned in this phase of testing. Due to the difference in height, of the transmitter and receiver, care will have to be taken to make the proper adjustments. Distance and accuracy of the laser system will be again observed and recorded.

With the addition of the second kart, new variables will be taken into account. Bumping will be tested extensively, to ensure the reliability of the components and mounting brackets. One again the handheld unit will be utilized to add an extra layer of testing, it will allow reaction times to be tested from the drivers dealing with outside sources affecting the flow of the driving.

7.3.2 Four Kart Testing

With the successful completion of two kart testing and additional two karts will be equipped with the laser system. This will be the first testing done on the Fun Spot race track and will heavily influence the game mechanics. The track will be outfitted with several temporary moveable colored mats for the item pick up and boost zones.

The focus of four kart testing will be on passing opportunities in race situations. By now the pick-up, laser and speed control systems will have been thoroughly tested. More fine tuning will be done with the timing lengths of the speed changes as well as the laser firing time. The colored mats will be moved around the course to determine where the best locations are for game enjoyment. Initial placement can be seen in figure 7.2.2.1. Green for boost zones, red for item pick up.



Fig 7.2.2.1

7.3.3 Full Race Testing

Once the best set up has been determined with the four kart testing, the remaining race karts will be equipped with the lazer kart system. This will be the ultimate test of the commercial viability of the game. The track will become more crowded, more bumping will occur, and jockeying for position will create different scenarios which will need to be monitored.

The main focus of this round of testing will be safety. By now, the system should be demonstrated to be functionally sound and durable. Tracking collisions when compared to races without the system will be done. It is expected that even though speed changes will occur more frequently, the ability to pass without the need for bumping will reduce the number of major collisions.

At the completion of full race testing, a determination will be made on permanent track implementation. At this point the LazerKart game system will be considered fully implemented, and work can begin on adding subsystems to increase the attraction to the Fun Spot ownership and customers.

7.4 Game Play Mechanics Testing

Once the final multi-kart testing is finished, the overall game play will continue to be fine tuned. The overriding goal from a commercial aspect of the LazerKart project is to get people to want to return to the race. It is at this point where rider feedback becomes important. With the ability to have up to 16 karts on the course at once, it will be possible to collect a large amount of data in a small time frame. During the initial implementation process, the team will be present for the race testing by the general public. Each rider will be asked to answer questions about the impression of the new system and to compare it to standard go-karting. The team will also be able to collect more ideas and suggestions for future improvements.

With the permanent track markings in place, the primary focus of the game play testing will be the manipulation of speed control timings, and lazer system fine tuning. With the addition of the optional ZigBee network, after initial implementation, new weapon modes may be added and play tested. Of interest would be a weapon that would disable all other cars on the track, and one that automatically disables the nearest car with ought having to aim, and one that disables the car with the most points. All of these weapons require the additional network module and display unit.

8.0 Administrative Content

8.1 Project Milestones

Project milestones are significant events or changes in the development of the project and were chosen to incorporate parallelism in order to achieve as much progress in research, design, testing and building as possible. The group subdivided the project into sections in order to achieve this time efficiency.

8.1.1 Spring 2013 – Senior Design I

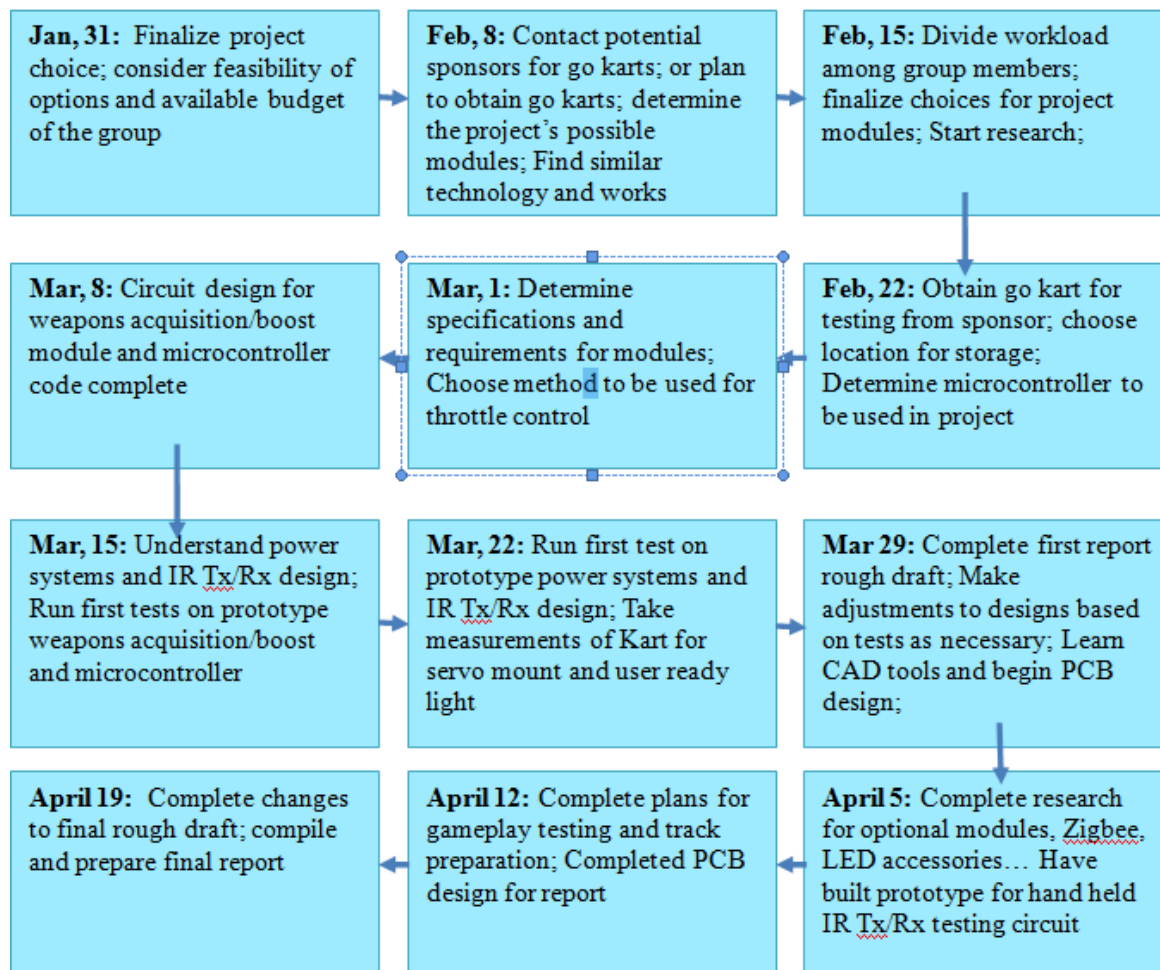

8.1.2 Fall 2013 Senior Design II

The main focus of the fall semester will be building, testing the systems, installation, track design and preparation. There will multiple karts to build which will also take time and top priority. Once PCBs have been ordered and the core system has been built the group will focus on installing the optional modules as time permits.

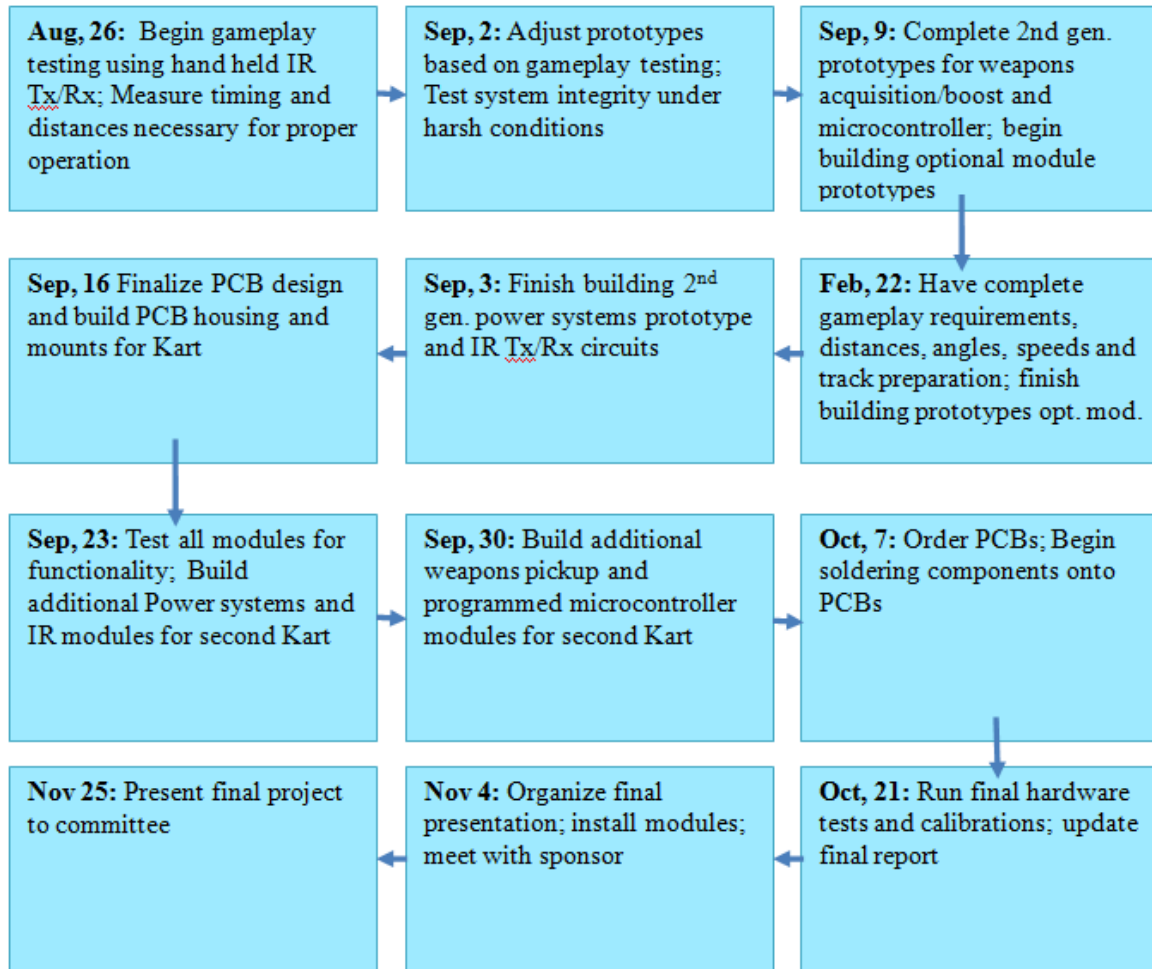

8.2 Equipment

- Tektronix CDM-250 Multi-Meter
- Tektronix 2465A 4-channel oscilloscope
- Bread-boards
- 6 gauge setting wire cutters
- 14 gauge wire
- 15' tape measurer
- Honda GX270 4-stroke engine
- 3/8' tapcon screw

- 19.5V drill
- 1/4" nut and bolts
- Servo arm throttle attachments springs
- Soldering kit, solder, solder pump etc.
- Tin Snips
- Dremel Tool and attachments

8.3 Accessories

- 30 RGB LED strip
- 8x8 RGB led display
- Waterproof terminal connectors
- Rubber mats
- 2-gal paint
- Zip ties
- Arrow marker stencil
- Aluminum sheeting
- Servo motor
- Hand held IR Tx/Rx
- TI Launchpad
- Laptop running TI Code Composer Studio
- PCB Enclosure and mounting hardware

8.4 Consultations

On several occasions we spoke with our professors for their opinion and insight regarding a module or the project in general. Before deciding to design laser karts we wanted to know about the feasibility of the weapons pick up concept. We decided to speak with Dr. Xun Gong about the cost, maturity and availability of technologies that would best fit the requirements of the weapons pick up system. First we described the project to Professor Gong and pointed out that the go karts would have a velocity of about 17mph and would need to detect the weapons on the track from approximately 6 inches away. Initially we had considered using RFID technology as means of detecting weapons on the track. We discussed the possibility of designing our own RFID tags to meet the requirements such as range and speed but found this to be more of a physics project rather than an electrical engineering project due to the complex electromagnetic field computations and material specifications that would be required as well as the fact that there are already many mature RFID technologies available for purchase. Once we ruled out designing our own RFID tags we then further discussed what types of technologies we could purchase.

The first technology discussed was the possibility of using a system similar to the electronic toll collection (ETC) used on highways, since these systems are used at high speeds and can detect tags from long distances. Professor Gong pointed out that the ETC systems are very high power and costly. We took the liberty of further exploring similar technologies and found that they are in fact costly, did not seem practical for the application we would be using them for and did not compete with other solutions such as the LED/photodiode approach.

On several occasions we spoke with Dr. Arthur Weeks. The first time meeting with him was to ask him for advice on where we should start as far as choosing parts for the power systems since there are so many available. Professor Weeks recommended that we look at the LT and TI website for rectifiers and regulators that meet the specifications of the power systems input and output. He pointed out that we could use TI's WEBENCH® in order to get an idea of what options are available as well as what we can design ourselves.

On another occasion we met with Dr. Weeks to further discuss the power systems in detail. After running our first test of the full-wave bridge rectifier we found that the diodes were burning up and needed to consult Dr. Weeks about a possible explanation and solution to this issue. He asked us to describe some of the characteristics of our power supplies signal such as what the shape frequency and amplitude are. Based on our description he said that the diodes are not able to handle the reverse bias current and that we would need to change them to Schottky diodes which can handle the rapid changes and in turn avoid burning them up. He also pointed out that we would need to change the capacitor values we were using in order to rectify the AC signal at the given frequencies.

Our last consultation with Dr. Weeks was to discuss the op-amp and LEDs as sensors. He described exactly what would happen in this configuration that matched the exact results obtained in testing. He declared that such a setup using LEDs as sensors, while fine for hobby use is not reliable for a functioning electrical engineering design. His recommendation was to use photodiodes set up in a current-to-voltage configuration with colored filters.

8.5 Budget

Module	Item	Cost/item	Qty (1 kart)	Purchased	Sub-total	Total
Power systems	Inductor	\$0.46	1	Sky Craft	\$0.46	
Power systems	Caps	\$1.50	2	Sky Craft	\$3.00	
Power systems	Regulators	\$4.00	2	LT/TI	\$8.00	
Power systems	Schottky diodes	\$0.59	4	Spark Fun	\$2.36	
Power systems	Resistors	\$0.15	6	Radio Rhack	\$0.90	
Power systems	AC coil terminals	\$0.40	2	Home Depot	\$0.80	
					\$15.52	\$15.52
Weapons pickup	Photo transistors	\$3.00	2	Vishay	\$6.00	
Weapons pickup	2-chnl Op-amp	\$0.50	1		\$0.50	
Weapons pickup	2-chnl Comparator	\$0.55	4		\$2.20	
Weapons pickup	Resistors	\$0.15	10		\$1.50	
					\$10.20	\$10.20
IR Tx/Rx	TSAL6100 LED	\$0.55	1	Vishay	\$0.55	
IR Tx/Rx	TSOP4856 Photo Module	\$1.17	1	Vishay	\$1.17	
IR Tx/Rx	ultrabright LED	\$0.95	8	Spark Fun	\$7.60	
IR Tx/Rx	Resistors	\$0.15	4		\$0.60	
IR Tx/Rx	PVC Pipe	\$2.83	1	Home Depot	\$2.83	
IR Tx/Rx	IR Filter	\$6.50	1	Edmund Optics	\$6.50	
IR Tx/Rx	Clear Dome	\$4.00	1	Surplus Shed	\$4.00	
					\$23.25	\$23.25
Microcontroller	MSP 430G2553	\$2.79	1	Digikey	\$2.79	
Microcontroller	Launchpad Programmer	\$4.30	1	TI	\$4.30	
					\$7.09	\$7.09
Fab	PCB enclosure	\$15.95	1	OKW Enclosures	\$15.95	
Zigbee					\$15.95	\$15.95
PCB		\$31.88	1		\$31.88	\$31.88
Core					\$0.00	
						\$103.89
Additional Costs						
Track	Paint	\$35.00	2	Home Depot	\$70.00	
Track	Rubber mats per foot	\$5.00	3	Home Depot	\$15.00	
Testing	Gas	\$10.00	3	Mobil	\$30.00	
Fab	shop work per hour	\$20.00	1	UCF wrk shp	\$20.00	
Accessory	30 RGB LED strip	\$20.00	3	Pololu	\$60.00	
Accessory	Water proof connectors	\$1.00	5	Molex	\$5.00	
Accessory	8x8 RGD display	\$35.00	1		\$35.00	
Servo	Corona 939MG	\$4.37	1	Hobby King	\$4.37	
Servo	Servo Mount	\$5.00	1	Home Depot	\$5.00	
No Bumping	Resisitors	\$0.15	2		\$0.30	
No Bumping	ADXL325	\$6.25	1	DigiKey	\$6.25	
No Bumping	LM393	\$0.55	1	DigiKey	\$0.55	
PCB	2 Pin PCB Terminals	\$1.00	12	Radio Shack	\$12.00	
PCB	3mm LED	\$0.35	1	Spark Fun	\$0.35	
PCB	20 Pin DIP Socket	\$0.11	1	Spark Fun	\$0.11	
PCB	MOSFET	\$0.95	2	Spark Fun	\$1.90	
PCB	Resisitors	\$0.15	2		\$0.30	
	Wire (20AWG)	\$8.99	1	Radio Shack	\$8.99	
					\$275.12	\$275.12
						\$379.01

9.0 Commercial Implementation

9.1 Track Preparation

9.1.1 Track Selection

During initial play testing, the three operational tracks at Fun Spot were tested to determine which track would be best suited for a first track to implement the system on. Things that were looked at included; areas for passing, track width, and appropriate areas for boost and weapon zone placement. The initial run was taken on the "Quad Helix" track. This track has several long straight-a-ways, as well as long sections of circling curves. The track width was consistent throughout. The next run was done on the "Conquest" track, which is smaller than the previous track, with a very steep downhill straight-a-way and a long circular climb. The final track tested was the "Thrasher" track which is considered a slick track, designed on one level and featuring many hairpin turns and varying widths of track.

After an initial run through of the tracks it was decided that the Thrasher was not suitable for the game purposes, due to the nature of the driving. Several more runs were taken on each of the other two courses. These subsequent runs involved simulated laser fire and braking, to test the length and times needed to allow for passing. Attention was put into the location of the passing, straight versus curved track, and uphill versus downhill. The results of this play testing concluded that the best option would be the Quad Helix track. The track was well suited for constant throttle racing, which should lend itself well to the game. The Commander track hill was determined to have been a possible safety concern for the game. Future play testing on all tracks is possible, but focus will be placed on the Quad Helix.

9.1.2 Game Setup

The main purpose of the game is to allow for the increase in passing, thereby making the experience more enjoyable for the rider. The setup chosen was designed to maximize these opportunities. In a typical go kart race, very little of the track is used if the drivers are even a little experienced. By placing the boost zones on the outside of the track, as indicated below by the green markings in Figure 9.1.2.1 more of the track will be used, and drivers can now weigh the benefits of taking the longer path to getting the speed boost. Timing of the boosts will be set to give the driver an good chance at passing the kart in front.

The red lines in Figure 9.1.2.1 indicate the positioning of the weapon pick up points. These are located so as to give the kart the ability to shoot while on the straight track, increasing the chance of a hit, and again, the opportunity to pass.



Figure 9.2.2.1

During play testing the locations of the zones will undoubtedly change, as more data becomes available. Initial track setup for testing will be done using movable zones, until an optimum setup has been chosen. Cardboard with the appropriate colors can be affixed to the track to hold enough for play testing will be removed for the permanent setup.

The final setup will consist of painted florescent stripes of appropriate color and width to be determined by play testing. Florescent paint is available at a cost of \$35 a gallon, and one gallon of each color should be sufficient to create the zones needed for the track. Track preparation will begin upon completion of the single kart play testing, for use in multiple kart play testing.

9.2 Staff Training

9.2.1 Game Operation Training

The ride operators at Fun Spot typically work in pairs, one operator at the beginning of the track, and one stationed in the middle of the track observe for unsafe conditions. The initial training will consist of explaining the new kart additions and what can be expected to change with the pace of the ride. The initial set up of the Lazer Kart will be a simple press of the reset button, which will enable game play. The ride operators will be instructed as to the location of the reset button.

The initial design is intended to be a simple version of the final product. As new features are added to the karts, the ride operators will be given instruction on their uses. Remote control of Karts and scoring will be additions which the game operators will be trained on.

9.2.2 In-Race Troubleshooting

During the course of play, it is inevitable that problems will occur with the system. The ride operators will be instructed on what common symptoms might occur, as well as possible solutions. The ideal situation is to fix the problem without removing the car from the track, and often the solution will be a simple reset of the unit. Staff will be trained to recognize when a more serious problem has occurred and when it is advised to remove the kart from the race.

9.2.3 Off Track Troubleshooting

The maintenance department will be trained more thoroughly than the ride operators, and will be given detailed instructions on the operation of the entire system. These personnel will be provided with circuit and wiring diagrams for the entire system, as well as a hands on walkthrough of the system by the design team. After initial implementation, it will be the maintenance department which will continue training new track operators on the proper operation of the system. As new revisions happen throughout the course of the design, the maintenance department will be re-trained to account for the changes.

9.3 Maintenance Training

The maintenance staff at Fun Spot will be given adequate training to ensure the proper operation of the LazerKart system. The basic troubleshooting flowchart shown below in figure 9.3.1 will be the first step towards maintenance and repair of the system.

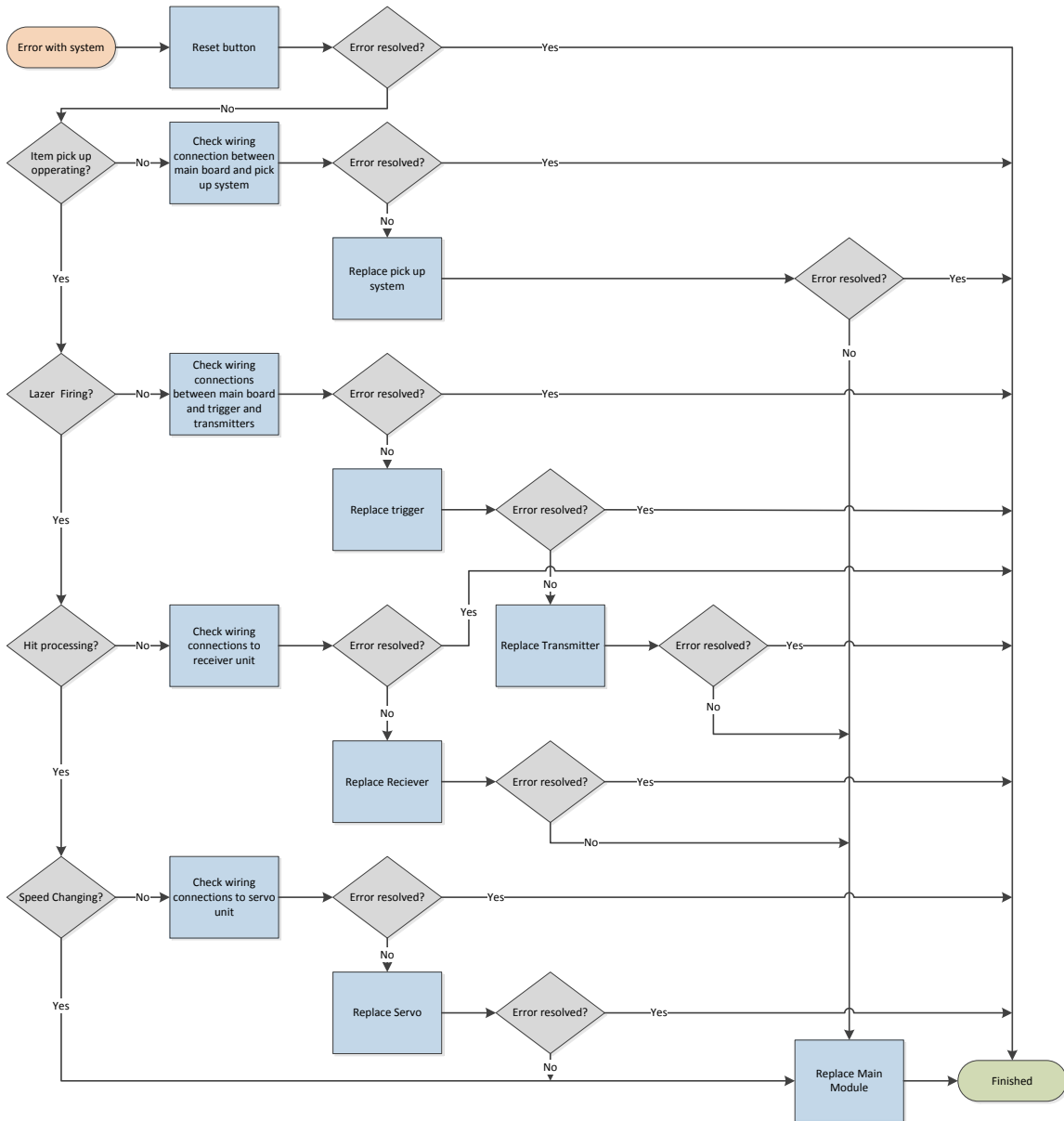

Fig 9.3.1

9.4 Stocking and Ordering Spare Parts

Fun Spot has a team of mechanics available to make repairs to and replace individual units of the LazerKart system. It is not expected that they will need to do any major troubleshooting, as the individual modules of the whole system are designed to be easily replaced, and relatively low cost. By following the flow chart given in section 9.3, it will be easy to determine the nature of the fault, and repairs will be quick.

With the initial plan to support one race track with the LazerKart system, a supply of 5 replacement components for each module will be sufficient. Because of the modular nature of the construction, no component level parts will need to be stocked, only fully built modules. In order to keep Fun Spot supplied with 5 working units, the team itself will be required to have parts on hand for the building of an additional 5 units. When the design is finalized, it is estimated that a lead time of no longer than one week would be necessary to resupply a fully functioning system.

If the system is shown to have a commercial appeal, distribution and resupply becomes a bigger piece of the puzzle. Effort will be made to standardize parts suppliers, to ensure consistency throughout the product line. With continued expansion, more data will become available to system longevity, and supply can be adjusted accordingly.

10.0 Summary and Conclusions

The culmination of this project, LazerKart, lies in the harmony of all subsystems and graceful execution of all gameplay mechanics. Through exhaustive research, extensive testing, and careful production, LazerKart is expected to be a stellar product that exceeds all expectations. The engineering team will bring a multitude of technologies together for a design that will not only impress those who are technically inclined but will also bring a smile to the average person who knows little of the inner workings involved.

Everything from wireless communication, embedded microcontroller programming, and power distribution to LED light displays and sound effects can potentially be employed in LazerKart, for a demonstration of a vast understanding of a multitude of technologies. The implementation is two-fold: not only will there be an academic reflection in LazerKart, but also a possibility for a marketable platform that could be low-cost and easy to maintain. The collective group feeling about the potential for LazerKart has been nothing short of positive and passionate, which has thus far helped to drive the progress in developing the concept further without getting discouraged.

Everything has seemed to fall into place at this point, with the sponsor, Fun Spot™, graciously donating a pristine go-kart to the group and Dixon Wheels and Sound of Sanford, Florida allowing the kart to be stored, tested, and developed on site. Furthermore, there seems to be ample power to supply to all of the basic subsystem components and inexpensive parts exist that allow these components to function as intended.

With pre-production well under way, as far as prototypes and working proof-of-concept demonstrations, LazerKart is on schedule to be swiftly developed and completed from connectors and PCB to brackets and enclosures by the end of Fall 2013 for not just one, but perhaps 4 or more go-karts.

Appendix A

References

“Mario Kart IRL”, Waterloo Labs, 2013 www.waterloolabs.com

“Multiple Integrated Lazer Engagement System”, Cubic Corporation, 2013
<http://www.cubic.com/Defense-Applications/Training-Systems/Multiple-Integrated-Lazer-Engagement-System>

“Electronics Description”, Combat TAG, LLC, 2013, <http://shop.lazertagparts.com/>

“Trace Current Carrying Capacity”, Armistead Technologies, 2013
<http://www.armisteadtechnologies.com/trace.shtml>

MSP430G2553 Datasheet, Texas Instruments, Inc. 2013

MSP430 User's Guide, Texas Instruments, Inc. 2013

ADXL 325 Datasheet, Texas Instruments, Inc. 2013

TSAL6100 Datasheet, Vishay Semiconductors GmbH, 2013

TSOP4856 Datasheet, Vishay Semiconductors GmbH, 2013

ETRX2-PA Datasheet, Telegesis (UK) Limited, 2013

Wave Shield Datasheet -v1.1., Adafruit Industries. <http://adafruit.com/> 15 Apr. 2013

Addressable RGB 30-LED Strip Datasheet, Pololu Robotics and Electronics. Web. 10 Mar. 2013.

“Extruded Aluminum Enclosures”, TEKO Enclosure Solutions. Web. 10 Apr. 2013.

“Is Lithium-ion the Ideal Battery?”, Battery University. Web. 3 Apr. 2013.

LT3008 Series Linear Regulator Datasheet, Linear Technology. Web. 16 Mar. 2013.

LT3014 Regulator Datasheet, Linear Technology. Web. 10 Apr. 2013.

LT1086 Datasheet, Linear Technology. Web. 2 Apr. 2013

Nickel Metal Hydride (NiMH) Handbook and Application Manual, Energizer. Web. 16 Feb. 2013.

Sealed Connectors Datasheet, Molex. Web. 18 Apr. 2013

“Welcome to Fun Spot Attractions”. Fun Spot. Web. 10, 15, 19 Feb. 2013.

“64 Pixel RGB LED Display – Another Arduino Clone”, Madworm, www.instructables.com. 23 Mar. 2013.

“8x8 RGB LED Matrix Display Module”, www.simplytronics.com. 23 Mar. 2013.

Graeme, Jerald (1996). Photodiode Amplifiers: Op Amp Solutions. McGraw-Hill.

Kuhn, Kenneth A. (2001, rev. 2008), “Use of Phototransistors”. www.KennethKuhn.com. 10 Mar. 2013.

“Making an Amplified Color Sensor from an LED and an OP Amp”, www.robotroom.com. 15 Feb. 2013.

Mancini, Ron (2001). Single-Supply Op Amp Design Techniques – SLOA030A. Texas Instruments Incorporated. 20 Feb. 2013.

Rako, Paul (2004). Photodiode Amplifiers: Changing Light to Electricity. National Semiconductor Corporation. 10 Apr. 2013.

Appendix B

Copyright Permissions

Texas Instruments Copyright Statement:

Reproduction of TI information in TI data books or data sheets is permissible only if reproduction is without alteration and is accompanied by all associated warranties, conditions, limitations, and notices. Reproduction of this information with alteration is an unfair and deceptive business practice. TI is not responsible or liable for such altered documentation. Information of third parties may be subject to additional restrictions.

You are more than welcome to use anything from our project to help build your own system. All I ask is that you send me a copy of your report when you're done. If you have any questions please let us know we are always game to answer technical questions over email, or we could even set up a Skype call if needed. Please let me know how we can help. Our goal in sharing this project was to inspire others so we want to support you however we can.

- Hunter Smith (Waterloo Labs)

From: Jeremy Feliciano [jeremy@pololu.com]
Sent: Thursday, April 18, 2013 2:52 PM
To: evan brown
Subject: Re: Letter of Consent

Hello, Evan.

Thank you for your interest in our products. You are welcome to use the text, files, and images from our website in your work as long as you give credit to us.

Please let me know if you have any additional questions or concerns.

Sincerely,
Jeremy Feliciano
(702) 262-6648
www.pololu.com

.....
Pololu Corporation
920 Pilot Rd.
Las Vegas, NV 89119
USA

From: John Hamburger [jhamburger@linear.com]
Sent: Monday, April 15, 2013 12:09 PM
To: evanb88@knights.ucf.edu
Cc: bscott@linear.com; treimund@linear.com
Subject: FW: Letter of consent

Evan,

You are welcome to use the specs and schematic for the regulators in your senior design project. You may consider this email as a permissions letter. Please credit Linear Technology Corporation for use. Thanks for your interest.

John Hamburger

John Hamburger
Director, Marketing Communications
Linear Technology Corp

-----Original Message-----

From: bscott@linear.com [mailto:bscott@linear.com]
Sent: Sunday, April 14, 2013 8:42 PM
To: jhamburger@linear.com
Cc: treimund@linear.com
Subject: Fw: Letter of consent

I imagine you have a standard letter of approval citing copyright, trademark etc., considerations to reply to this.

*****LINEAR TECHNOLOGY CORPORATION*****Internet Email Confidentiality Footer*****This e-mail transmission, and any documents, files or previous e-mail messages attached to it may contain confidential information that is legally privileged. If you are not the intended recipient, or a person responsible for delivering it to the intended recipient, you are hereby notified that any disclosure, copying, distribution or use of any of the information contained in or attached to this transmission is STRICTLY PROHIBITED. If you have received this transmission in error, please immediately notify me by reply e-mail, or by telephone at (408)433-5724, and destroy the original transmission and its attachments without reading or saving in any manner. Thank you.

Advanced Enclosures for today's electronics...



Mr. Evan Brown
University Of Central Florida
404 Timberglen Court
Winter Springs, FL 32708

Dear Mr. Brown

Our Ref: TEKAM.13.04.19

Date: 4/19/13

Hi Evan,
Thank you for the inquiry.

Please accept this letter as confirmation to use the Tekam image in your project. We are very interested in how our cases are used. Please if possible send us a picture so we can share with TEKO.

Yours sincerely

Ray Toubo
Office Manager
rayt@okwenclosures.com